

MASTERYS BC

15 - 40 kVA

安装及操作手册 (CN)

Installations- und bedienungsanleitung (DE)

Manual de instalación y uso (ES)

Manuel d'installation et d'utilisation (FR)

Installation and operating manual (GB)

Manuale di installazione e uso (IT)

Installatie- en bedieningshandleiding (NL)

Dokumentacja Techniczno-Ruchowa (PL)

Manual de instalação e funcionamento (PT)

Manual de instalare și utilizare (RO)

Руководство по установке и эксплуатации (RU)

Navodila za priključitev in uporabo (SI)

Kurulum ve kullanım kılavuzu (TR)



CERTIFICATE AND CONDITIONS OF WARRANTY

This SOCOMEC UPS continuous power system is guaranteed against any manufacturing or material defects.

The warranty is valid for 12 (twelve) months from the commission date, provided activation is carried out by SOCOMEC UPS personnel or personnel from a support centre authorised by SOCOMEC UPS, and no more than 15 (fifteen) months from being shipped from SOCOMEC UPS.

The warranty is valid throughout national territory. If the UPS is exported abroad, the warranty will only cover the parts used to repair faults.

The warranty is valid ex-works and covers labour and parts used to repair the faults.

The warranty shall not apply in the following cases:

- Failure due to unforeseen circumstances or force majeure (lightning, floods, etc.);
- Failure due to negligence or improper use (use outside limits: temperature, humidity, ventilation, electric power supply, applied load, batteries);
- Insufficient or inappropriate maintenance;
- When maintenance, repairs or modifications have not been carried out by SOCOMEC UPS personnel, or personnel from a support centre authorised by SOCOMEC UPS.
- If the battery has not been recharged in accordance with the terms indicated on the packaging and in the manual, in the event of long periods of storage or UPS inactivity.

SOCOMEC UPS may, at its own discretion, opt for the repair of the product or the replacement of faulty or defective parts with new parts, or with used parts of equivalent quality to new parts with regard to function and performance.

Defective or faulty parts replaced free of charge must be made available to SOCOMEC UPS, which becomes the sole owner.

Replacement or repair of parts, or any modifications to the product during the warranty period, will not extend the duration of the warranty.

SOCOMEC UPS will not be responsible for damages under any circumstances (including, without limitations, damage for loss of earnings, interruption of activity, loss of information or other financial losses) arising from the use of the product.

These conditions are subject to Italian law. Any disputes fall under the jurisdiction of the Court of Vicenza.

SOCOMEC UPS retains the full and exclusive ownership rights to this document. Only a personal entitlement to use the document for the application indicated by SOCOMEC UPS is granted to the recipient of this document. The reproduction, modification, distribution of this document, either partially or wholly and in any manner, is strictly prohibited except upon Socomec's express prior written consent.

This document is not a specification. SOCOMEC UPS reserves the right to make any changes to the information provided without prior notice.

SUMMARY

| | |
|---|----|
| 1. SAFETY STANDARDS | 4 |
| 1.1. IMPORTANT | 4 |
| 1.2. DESCRIPTION OF SYMBOLS USED ON LABELS ATTACHED TO THE UNIT | 5 |
| 2. UNPACKING AND INSTALLATION OF THE UNIT | 6 |
| 2.1. SHIPPING AND MOVING | 6 |
| 2.2. UNPACKING PROCEDURE | 7 |
| 2.3. ENVIRONMENTAL REQUIREMENTS | 10 |
| 2.4. ELECTRICAL REQUIREMENTS | 11 |
| 2.5. INSTALLATION PROCEDURES AND INSTRUCTIONS | 13 |
| 2.6. GENERATOR CONNECTION | 15 |
| 2.7. EXTERNAL ESD CONNECTION | 15 |
| 2.8. ISOLATION TRANSFORMER | 16 |
| 2.9. UPS PARALLEL CONFIGURATION | 16 |
| 2.10. EXTERNAL BATTERY CABINET CONNECTION | 19 |
| 3. MODES OF OPERATION | 20 |
| 3.1. ON LINE OPERATION | 20 |
| 3.2. OPERATION IN HIGH EFFICIENCY MODE | 20 |
| 3.3. OPERATION WITH MANUAL MAINTENANCE BYPASS | 20 |
| 3.4. OPERATION WITH EXTERNAL MANUAL BYPASS | 21 |
| 4. ACCESS TO CONTROLS | 22 |
| 4.1. IDENTIFYING SWITCHES AND INTERFACES | 22 |
| 4.2. SWITCH FUNCTIONS | 23 |
| 5. MIMIC PANEL | 24 |
| 5.1. BASIC MIMIC PANEL | 24 |
| 6. OPERATING PROCEDURES | 31 |
| 6.1. START-UP IN NORMAL MODE | 31 |
| 6.2. SHUTDOWN | 31 |
| 6.3. EXTENDED OUT OF SERVICE | 31 |
| 6.4. SWITCHING ONTO MANUAL BYPASS | 32 |
| 6.5. EMERGENCY SHUTDOWN (ESD) | 32 |
| 7. CONNECTIVITY AND COMMUNICATION OPTIONS | 33 |
| 7.1. MULTI-LEVEL COMMUNICATION | 33 |
| 7.2. ADC CARD / ADC CARD WITH TEMPERATURE SENSOR | 34 |
| 7.3. REMOTE MIMIC PANEL | 35 |
| 7.4. NET VISION LAN/WEB INTERFACE | 35 |
| 7.5. PROFIBUS INTERFACE | 35 |
| 7.6. SOFTWARE OPTIONS | 35 |
| 8. TROUBLESHOOTING | 36 |
| 8.1. SYSTEM ALARMS | 36 |
| 8.2. UPS ALARMS | 37 |
| 8.3. PREVENTIVE MAINTENANCE | 37 |
| 9. ELECTRICAL OPTIONS | 39 |
| 9.1. INSULATION CONTROLLER | 39 |
| 9.2. EXTERNAL MAINTENANCE BYPASS | 39 |
| 9.3. EXTERNAL MAINTENANCE BYPASS WITH BACKFEED PROTECTION | 39 |
| 9.4. ACS PCB | 39 |
| 9.5. EXTERNAL BACKFEED PROTECTION | 39 |
| 9.6. PROTECTION ON THE SEPARATE AUXILIARY MAINS | 40 |
| 9.7. PROTECTION ON A UPS WITHOUT AUXILIARY MAINS SUPPLY | 41 |
| 10. TECHNICAL SPECIFICATIONS | 42 |

1. SAFETY STANDARDS

1.1. IMPORTANT

- This document provides important instructions for the safe use, movement and connection of the MASTERYS BC uninterruptible power system (UPS).
- SOCOMEC UPS retains the full and exclusive ownership rights over this document. Only a personal entitlement to use the document for the application indicated by SOCOMEC UPS is granted to the recipient of this document. The reproduction, modification, distribution of this document either partially or wholly and in any way is strictly prohibited except upon Socomec's express prior written consent.
- This document is not a specification. SOCOMEC UPS reserves the right to make any changes to the information provided without prior notice.
- The unit must only be installed and activated by qualified technical personnel who have been authorised by SOCOMEC UPS.



The UPS MUST only be moved by two people at least.
They MUST take position at the sides of the UPS with respect to the direction of movement.

- The unit must remain in a vertical position at all times.
- Connect the PE ground conductor first before making any other connection.
- Do not expose the UPS to rain or liquids in general. Do not insert foreign bodies.



The installer is responsible for implementing the backfeed protection with the use of AC input line isolation devices external to the UPS (see section 2.4.1).

Before working on this circuit

- Isolate the Uninterruptible Power System (UPS)
- Then check for Hazardous Voltage between all terminals including the protective earth



Risk of Voltage Backfeed

- For the purpose of warning electrical technicians against backfeed situations not caused by the UPS, which may arise when a particular load fault is present while the UPS is operating in stored energy mode, or while unbalanced loads are supplied through a particular power distribution system e.g. an impedance grounded IT system, the installer must attach the labels provided to all primary power isolators installed remotely from the UPS area and on external access points, if present, between the said isolators and the UPS.

In particular the label must be attached to the external AC input line isolation service (backfeed insulation).

- Keep this manual in a convenient place for future consultation.
- If the unit fails, it must only be repaired by authorised technicians who have been specially trained for this purpose.
- This equipment complies with European Community directives for industrial equipment and bears the approval mark 
- The UPS requires three-phase plus neutral input connections (3P+N).
- Do not connect the output neutral to ground. The UPS does not modify the neutral setup of the system; the use of an isolation transformer is required should it be necessary to modify the neutral setup downstream of the UPS.
- Before connecting any external battery cabinets, ensure they are fully compatible with the UPS model used.
- The use of external battery cabinets not supplied by the manufacturer is not recommended.
- Switch off and isolate the UPS and wait for 5 minutes before removing the protection panels in order to carry out work on parts under dangerous voltage.
- Risk of explosion if the batteries are replaced with others of the wrong type.
- Used batteries must be disposed of at authorised waste disposal centres.



It is very dangerous to touch any part of the batteries as there is no insulation between the batteries and the mains power source.



CAUTION!
A battery can present a risk of electrical shock and high short circuit current.

The following precautions should be observed when working on batteries:

- a) Remove watches, rings or other metal objects.
- b) Use tools with insulated handles.
- c) Wear rubber gloves and boots.
- d) Do not lay tools or metal parts on top of batteries.
- e) Disconnect the charging source prior to connecting or disconnecting battery terminals.
- f) Determine if battery is inadvertently earthed. If inadvertently earthed, remove source from earth. Contact with any part of an earthed battery can result in electric shock. The likelihood of shock can be reduced if earthing is removed during installation and maintenance (applicable to equipment and remote battery supplies with no earthed supply circuit).

The product you have chosen is designed for commercial and industrial use only.

If used for particular critical applications such as life support systems, medical applications, commercial transportation, nuclear facilities or any other application or systems where product failure is likely to cause substantial harm to people or property, the products may have to be adapted.

For such use please contact SOCOMEC UPS beforehand to check if these products meet the required level of safety, performance, reliability and comply with applicable laws, regulations and specifications.

1.2. DESCRIPTION OF SYMBOLS USED ON LABELS ATTACHED TO THE UNIT

All precautions and warnings on labels and plates inside and outside the equipment should be observed.



DANGER! HIGH VOLTAGE (BLACK/YELLOW)



GROUND TERMINAL



READ THE USER MANUAL BEFORE USING THE UNIT

2. UNPACKING AND INSTALLATION OF THE UNIT

The packaging guarantees the stability of the UPS during shipping and physical transfer. Carry the packaged unit as close as possible to the installation site.



When moving the unit on even slightly sloping surfaces, use the blocking equipment and braking devices to ensure that the unit does not fall over.

2.1. SHIPPING AND MOVING

- The UPS must remain in a vertical position during all shipping and moving operations.
- The unit has wheels that can be used to move it for short distances.
- Ensure the floor is strong enough to support the weight of the UPS and battery cabinet, if used.



Avoid pressing on the front panels when moving the unit.



The UPS **MUST** only be moved by two people at least. They **MUST** take position at the sides of the UPS with respect to the direction of movement.



CAUTION IF DAMAGED NON-SPILLABLE BATTERIES

If packaging is crushed, ripped or open such that the inner contents are revealed, the equipment should be kept in an isolated area and inspected by a qualified person. If the packaging cannot be shipped the contents should be collected promptly, kept apart, and the sender or recipient should be contacted.

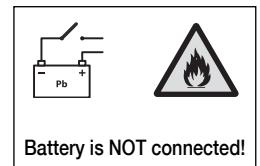

All packaging must be recycled in compliance with existing legislation in the country where the system is installed.

2.2. UNPACKING PROCEDURE

2.2.1. S Models (h 800 mm) and M Models (h 1000 mm)

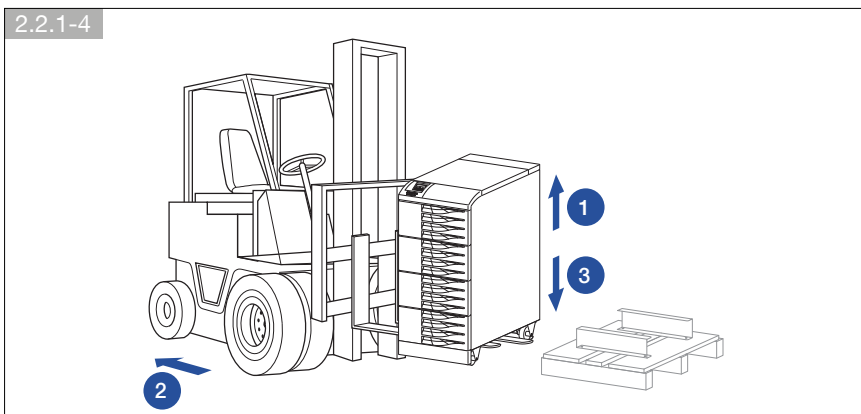
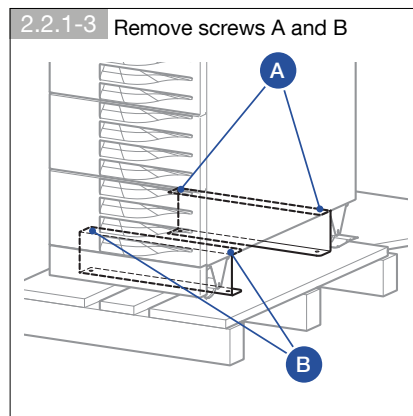
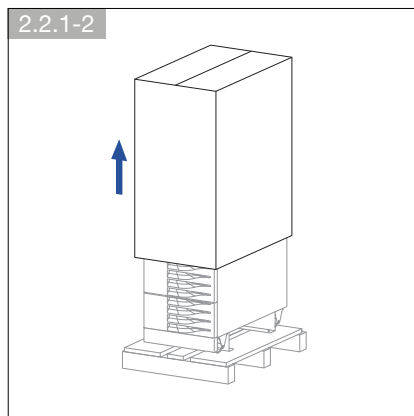
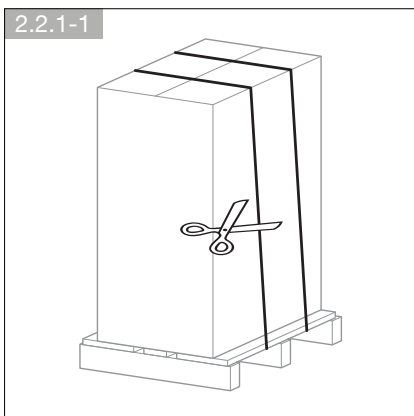

The UPS can be moved.
Place the UPS in the installation area.

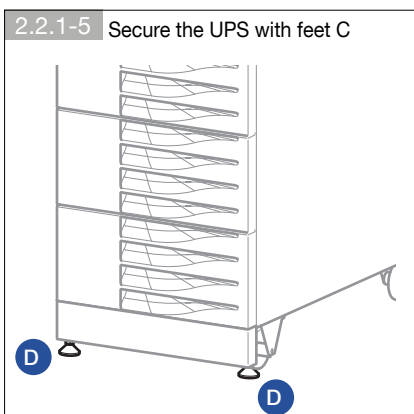

Secure the UPS with feet D
only when it is in position with
cables connected.

2. UNPACKING AND INSTALLATION OF THE UNIT

2.2.2. T Models (h 1400 mm)

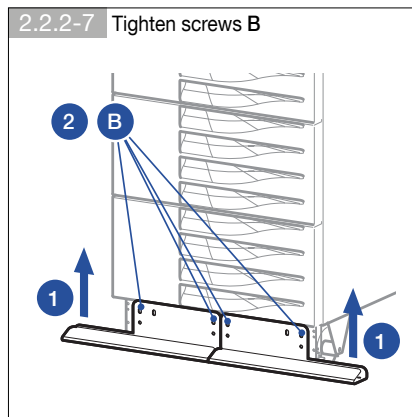
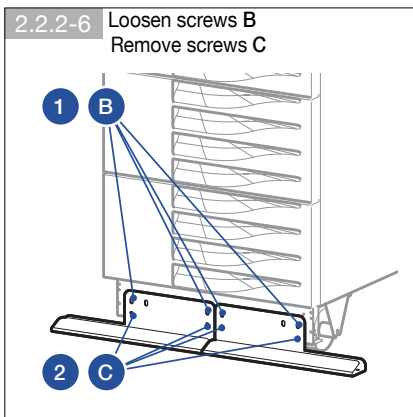
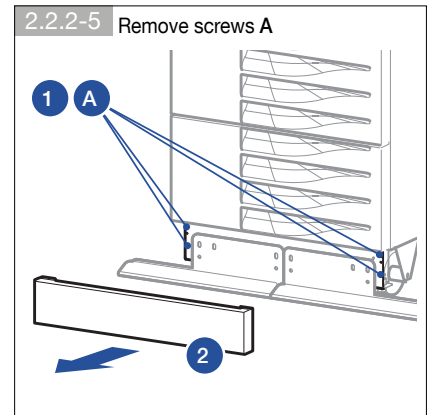
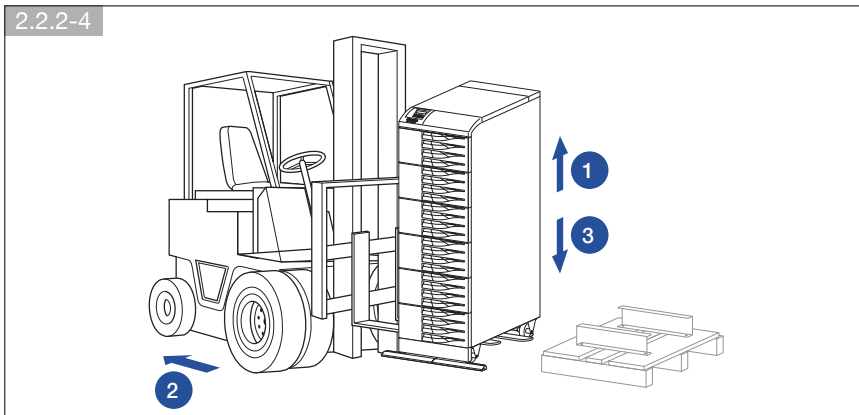
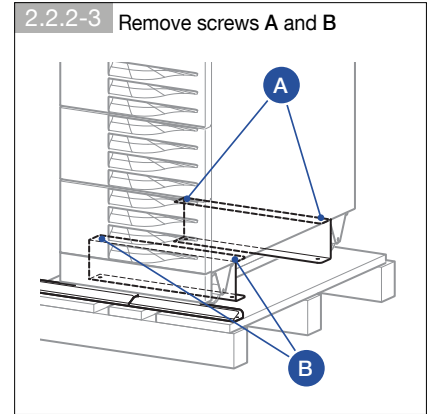
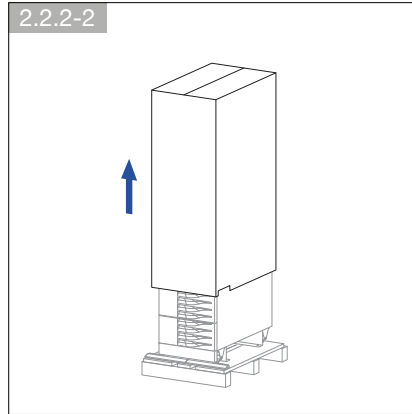
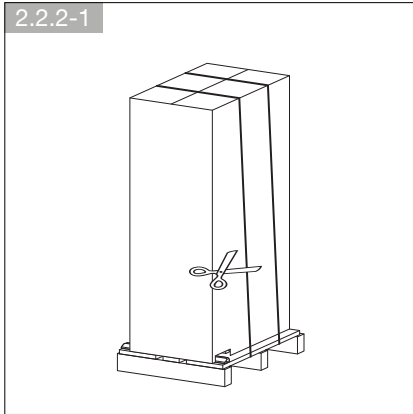

 The UPS can be moved.
Place the UPS in the installation area.

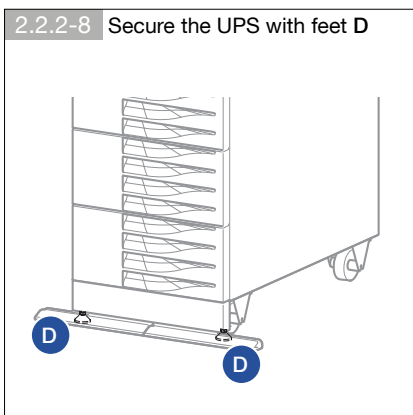

 Secure the UPS with feet D only when it is in position with the cable connected.

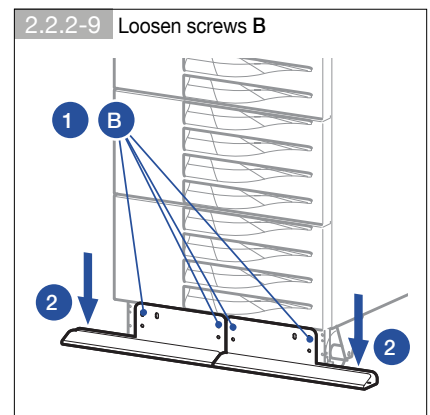

2. UNPACKING AND INSTALLATION OF THE UNIT

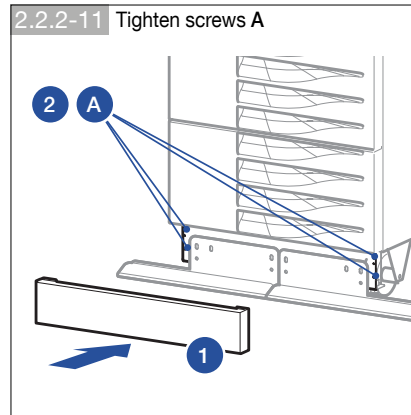
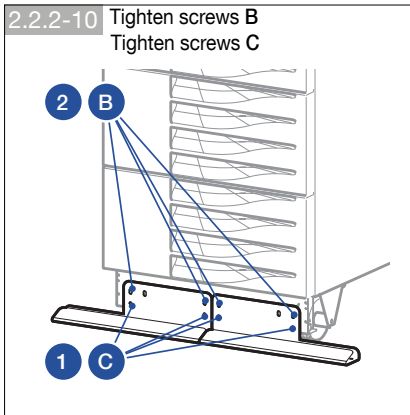

For UPS 15-40kVA height 1400mm without internal battery:

- with battery cabinet fitted alongside: remove leveller E from the cabinet. Fasten the UPS to the cabinet using the bracket E supplied (figure 2.2.2-12).
- without battery cabinet fitted alongside: secure the UPS to the floor (figure 2.2.2-13).

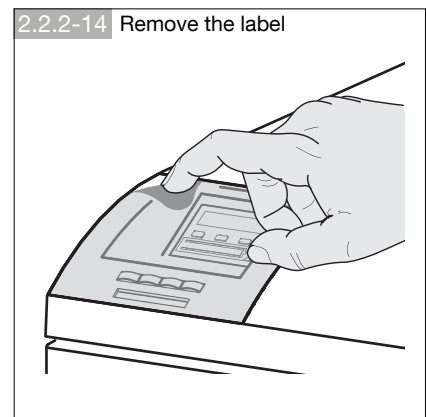
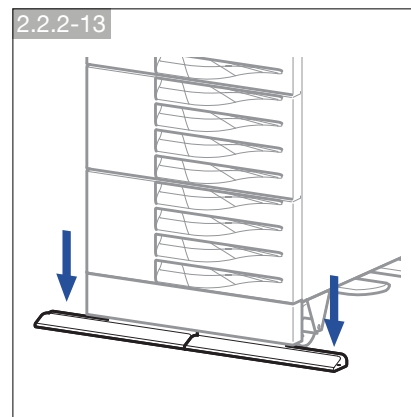
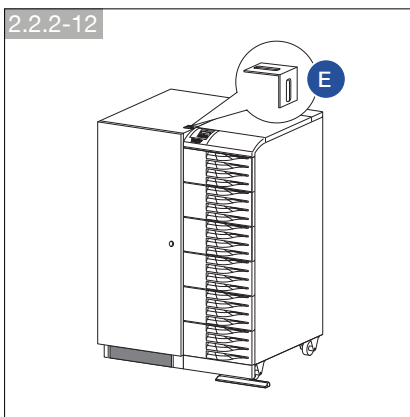

2.3. ENVIRONMENTAL REQUIREMENTS

- The recommended operating temperature, humidity and altitude values are listed in the technical specifications table (see chapter 10). Cooling systems may be required to maintain these values.
- Avoid dusty environments or areas where there is dust from conductive or corrosive materials (e.g. metal dust or chemical solutions).
- The UPS is not designed for outdoor use.
- Do not expose the UPS to direct sunlight or sources of excessive heat.
- A space of at least 40 cm must be left at the back for adequate ventilation (see figure 2.3-1).
- The UPS switches are accessed from the front; however, a space of at least 1.5 metres should be left at the front of the UPS for maintenance purposes. It is also advisable to ensure that the cable connections are sufficiently long and flexible so that the unit can be extracted during maintenance (see figure 2.3-2).
- If it is not possible to leave sufficient space at the front, adequate access must be ensured from both sides.

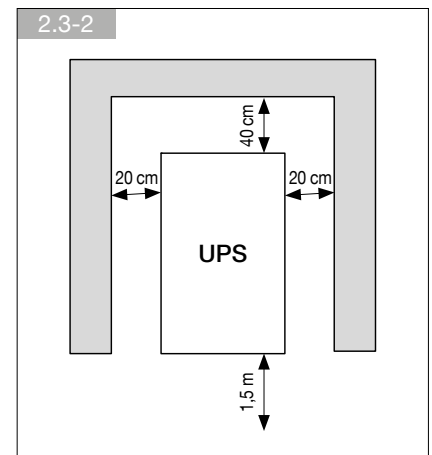
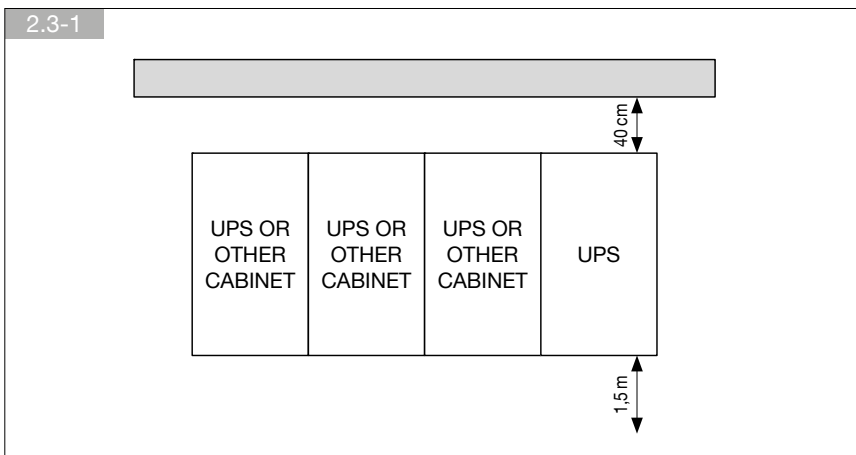

2.4. ELECTRICAL REQUIREMENTS

The installation and system must comply with national plant regulations.

The electrical distribution panel must have a protection and sectioning system installed for the input mains and the auxiliary mains. If a differential switch is installed on the mains power switch (optional), it must be inserted upstream from the distribution panel.

The table below shows the size of the input protection devices recommended for correct installation.

| Size of the input protection devices | | | | | | | | | | |
|--------------------------------------|-------------------------------------|-------------------------------------|--|-----------------------|---------------------------------|-----------------------------------|------------------|-------------------------|------------------|---------------------------------|
| UPS | Magneto-thermal input ¹ | | Magneto-thermal Aux Mains ¹ | | Differential input ⁵ | Input/Output cable core size | | Battery cable core size | | Battery protection ⁴ |
| (kVA) | (A) | | (A) | | (A) | (mm ²) | | (mm ²) | | (A) |
| | single | parallel ² | single | parallel ² | selective type ⁵ | Min | Max ³ | Min | Max ³ | |
| 15 3/1 | 32 | 40 | 100 | 125 | 0.5 | 6 | 35 | 6 | 35 | 50 Gr |
| | 100 <i>if common input mains</i> | 125 <i>if common input mains</i> | | | | 25 <i>aux mains and output</i> | | | | |
| 20 3/1 | 40 | 63 | 125 | 160 | 0.5 | 10 | 35 | 10 | 35 | 63 Gr |
| | 125 <i>if common input mains</i> | 160 <i>if common input mains</i> | | | | 35 <i>aux mains and output</i> | | | | |
| 15 3/3 | 32 | 40 | 32 | 40 | 0.5 | 6 | 35 | 6 | 35 | 50 Gr |
| 20 3/3 | 40 | 63 | 40 | 63 | 0.5 | 10 | 35 | 10 | 35 | 63 Gr |
| 30 3/3 | 63 | 80 | 63 | 80 | 0.5 | 16 | 35 | 16 | 35 | 100 Gr |
| 40 3/3 | 80 | 100 | 80 | 100 | 0.5 | 25 | 35 | 25 | 35 | 125 Gr |

¹ Recommended magneto thermal switch: four poles with intervention threshold $\geq 10 I_n$ (curve C). It is necessary to use a D curve selective breaker if an optional external transformer is used.

² In systems with two or more UPSs operating in a redundant or power parallel configuration.

³ Determined by the size of the terminals.

⁴ Protection on the external battery cabinet (preferably 2 bipolar protection devices or one quadripolar).

⁵ Caution! Use type B selective (S) circuit breakers. Load leakage currents are added to those generated by the UPS and during transitory phases (power failure and power return) short current peaks may occur. If loads with high leakage current are present, adjust the differential protection. It is advisable in all cases to carry out a preliminary check on the earth current leakage with the UPS installed and operational with the definitive load, so as to prevent the sudden activation of the above switches.



The UPS is designed for transitory overvoltages in category II installations. If the UPS is part of the building's electric circuit or is likely to be subject to transitory overvoltages in category III installations, further external protection must be provided, either on the UPS or in the AC power supply network connected to the UPS. Additionally, the 'surge arrester' option, specially designed to protect against residual overvoltages in category III installations, can be installed in the external manual bypass cabinet. If used, the distance between the UPS and the centralised 4 kV SPD protection device type 1 must be $U_p \leq 4kV$ is $\geq 15m$.



In the event of three-phase distorting loads connected in output, the current on the neutral conductor may have a value that is 1.5-2 times the phase value (also for the input bypass). In this case, size the neutral cables and the input/output protection adequately.



WARNING!

This is a product for commercial and industrial application in an industrial environment - installation restrictions or additional measures may be needed to prevent interference.



IMPORTANT!

Protective earthing conductor (PE) must have sufficient current-carrying capacity.

The PE cable core size must be chosen according to the PROTECTIVE CURRENT RATING of the earth circuit which depends on the provision and location of protective overcurrent devices.

2.4.1. Backfeed protection

If the UPS does not have an automatic protection device against current backfeed, the operator/installer must add a warning label to all the mains power disconnecting switches installed at a distance from the UPS area. This serves to remind technicians of the fact that the circuit is connected to a UPS (see the SAFETY section in paragraph 1 of this manual and paragraph 4.7.3. of the EN62040-1 2009-05 standard).

The label is supplied with the system.

The backfeed protection device may be built into the system (only on specific request), or an electromechanical switch may be installed externally in the input of the UPS.

- If the UPS incorporates this protection, proceed with the connections as described in paragraph 2.5 of this manual.
- To install the external backfeed protection it is necessary to use the BKF card and an external electromechanical switch that should be installed. For further information on the connection and the type of remote switch, please read paragraph 9.7 of this manual.



WARNING

The neutral is not disconnected as, even in the event of a single fault on the UPS, it never has high potential when the mains and/or auxiliary power supplies are disconnected upstream. This is to prevent transformation of the power source to the UPS every time there is a power failure.

If under certain irregular conditions, or due to the installation upstream (e.g. undetected and protected earth fault, or high leakage in a phase, or with IT systems) there is a hazardous potential on neutral, a suitable isolating switch must be provided on the neutral as well, or else there must be a detection, signalling and protection system.



NOTE

For equipment with separate Emergency Mains, the neutral of the Emergency Mains line must be electrically common with the neutral of the main input feed line.

2.5. INSTALLATION PROCEDURES AND INSTRUCTIONS



WARNING!

Before carrying out work on the terminal board or on UPS internal parts, ensure that the UPS is switched off, remove the power supply, open the external battery cabinet disconnectors, isolate the system and wait 5 minutes.

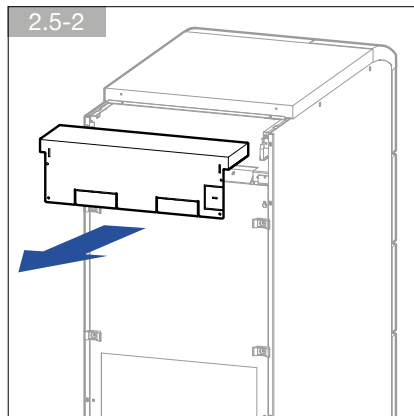
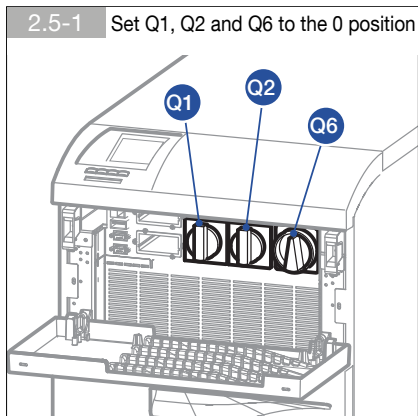

Cable specifications:

- strip length: 18 mm
- tightening torque: 2.5 - 4.5 Nm

3/3 Connections if THE MAINS AND AUX MAINS ARE CONNECTED IN COMMON

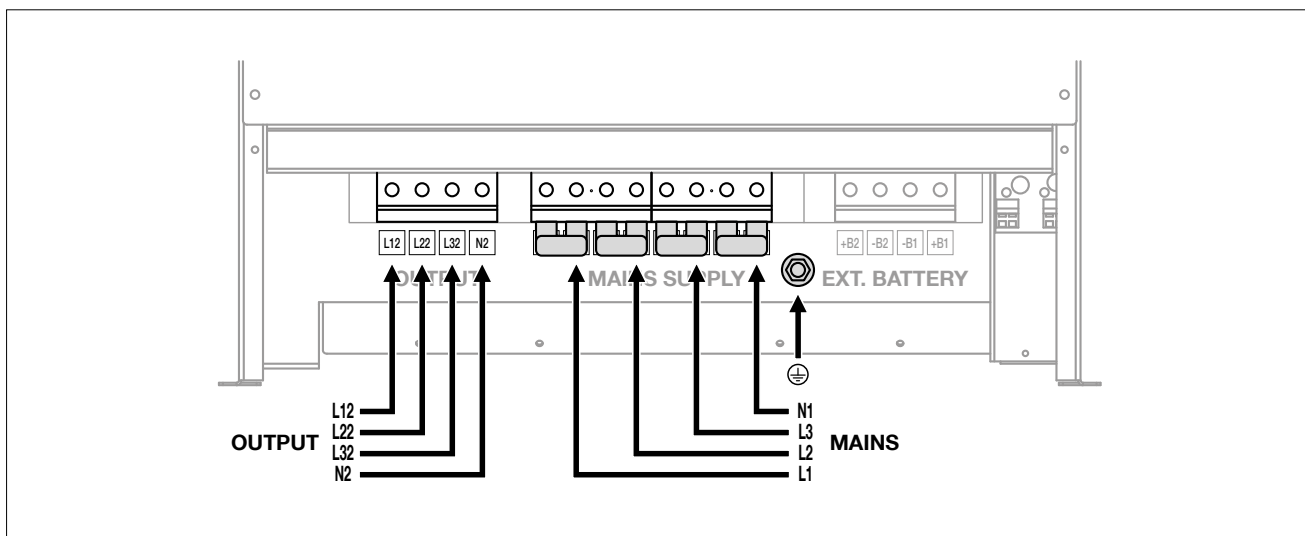

2. UNPACKING AND INSTALLATION OF THE UNIT

3/3 Connections if THE MAINS AND AUX MAINS ARE CONNECTED SEPARATELY

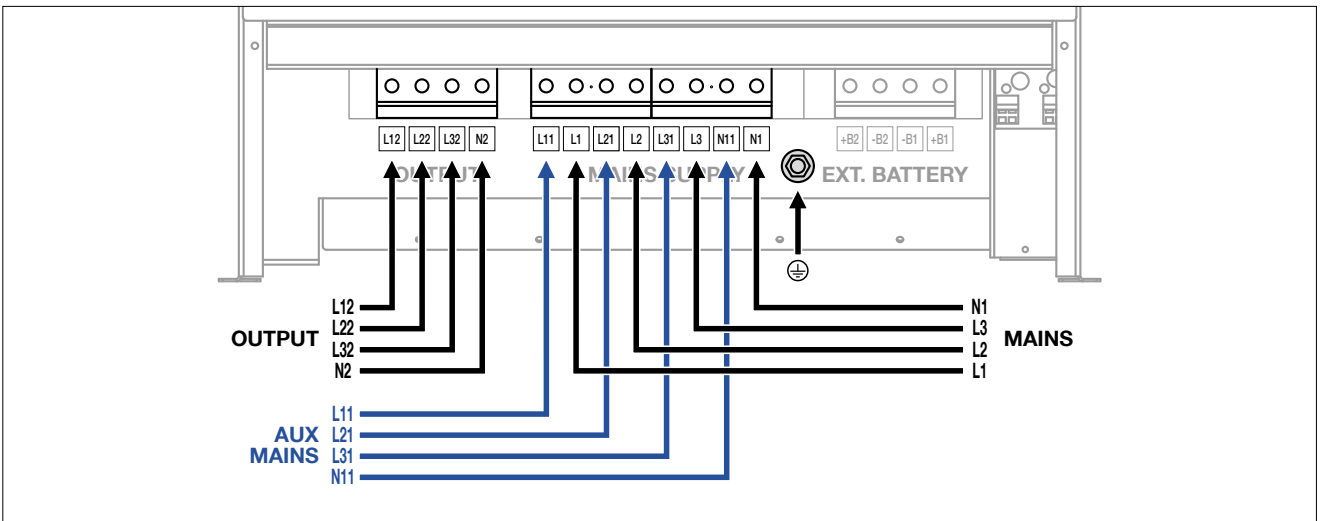
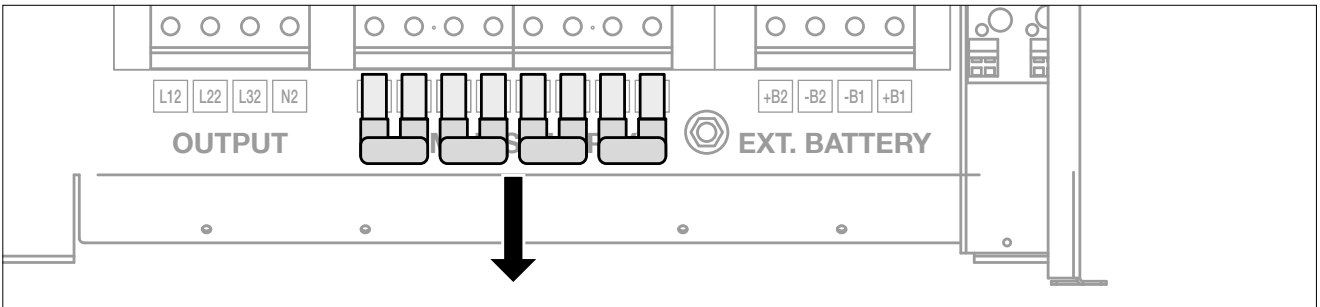

3/1 Connections if THE MAINS AND AUX MAINS ARE CONNECTED SEPARATELY

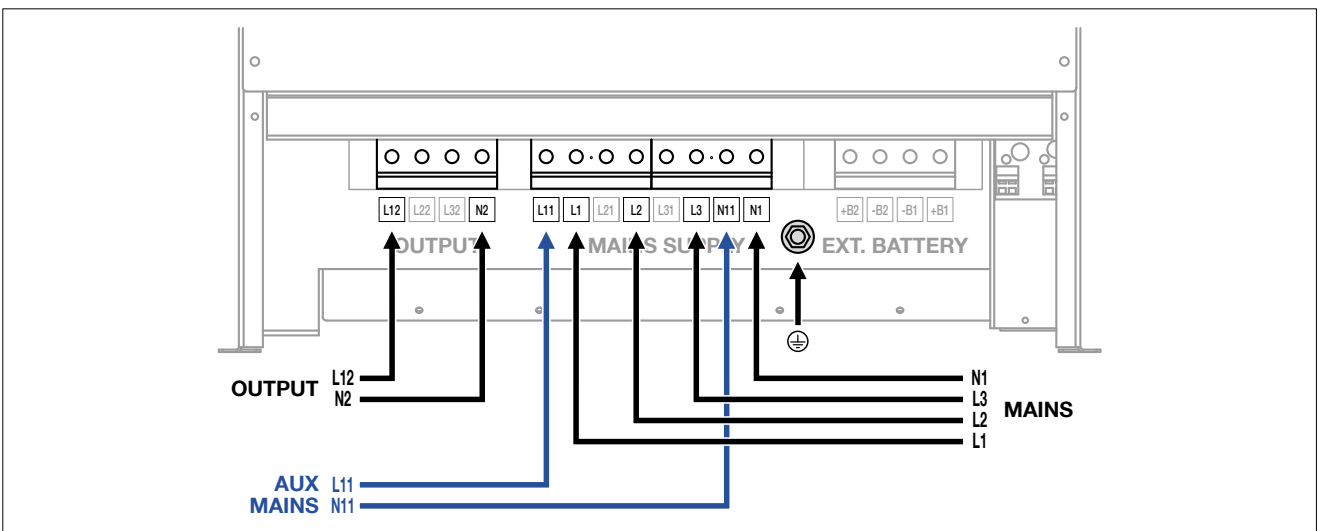

2. UNPACKING AND INSTALLATION OF THE UNIT

- 2.5-3** Guide any control cables from the front (RS232, signalling relay contacts, etc.) into the appropriate side cable run **A**.
- 2.5-4** Remove the pre-cut element **C** and bend elements **B** to feed through the cables, secure the terminal board cover with the four screws.
- 2.5-5** Secure the cables to the couplings **D** located on the rack ensuring that the air vents are not obstructed in any way.
- 2.5-6**  **Once cabling has been carried out, secure the UPS with the fixing feet E**
- 2.5-7** If the system is installed on a raised floor (such as in a data processing room):
- leave a space of at least 20 cm between the power and the control cables;
 - avoid parallel channelling over long distances; choose cables crossing at 90° instead.

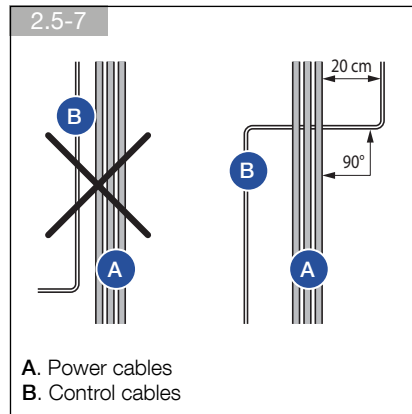
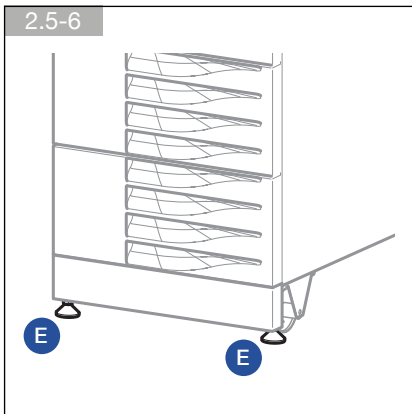
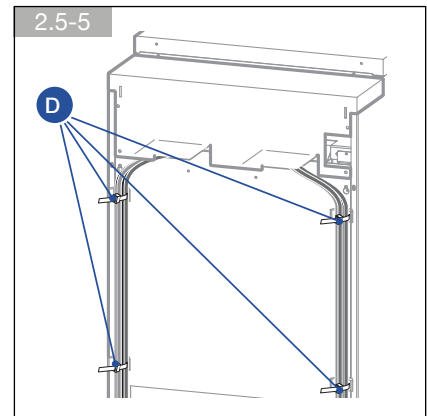
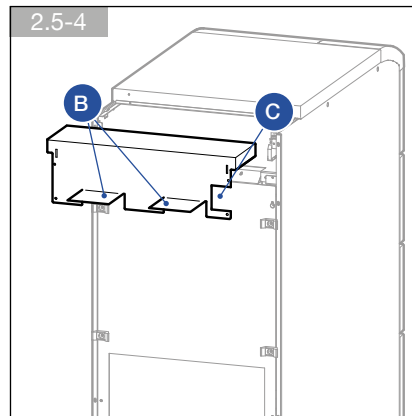
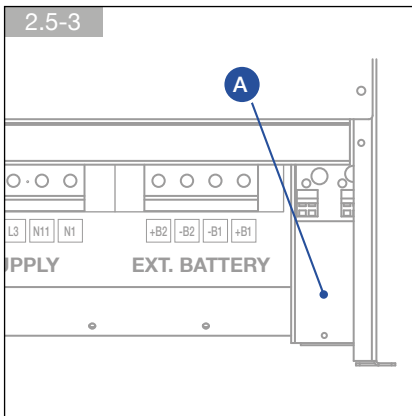

2.6. GENERATOR CONNECTION

If your system uses a generator, connect the 'generator set ready' no-potential contact to connector **IN 2** on the optional ADC PCB configured in standard or power safe mode. This automatically extends the voltage and frequency value range when power is supplied by the generator set.

2.7. EXTERNAL ESD CONNECTION

A remote emergency shutdown system (ESD) can be installed by means of the optional ADC PCB. Connect a normally closed zero-potential contact to terminals **IN1+** and **IN1-** of the ADC PCB.

2.8. ISOLATION TRANSFORMER

If an external isolation transformer cabinet is required, the following instructions should be followed:

- Refer to chapters 1 and 2 of this manual for indications on moving and installing the cabinet.
- See paragraph 2.4 for details about protection devices.
- The protection cable marked with the ground symbol is connected directly to the distribution panel.
- The transformer can either be connected to the UPS input or output.



The UPS must not operate without the neutral connection to the input.

The transformer cannot be connected to the output on individual UPS units connected in parallel configuration.

For connection details refer to the transformer terminal board diagram.

2.9. UPS PARALLEL CONFIGURATION

2.9.1. General

Parallel connection enhances UPS system reliability, performance and power.

All MASTERYs models can be installed in parallel configuration provided they have the special parallel kit that can be installed in the factory or later by specialist personnel.

UPS modules for parallel operation are identical to standard UPS modules, as a result safety, shipping and installation recommendations in chapters 1 and 2 also apply.

2.9.2. Installation

UPS units operating in parallel are interconnected using control cables **B** (fig. 2.9.3-1) and are configured differently depending on the position they are assigned.

For this reason the units have a position label **C** (Fig. 2.9.3-1):

- The LEFT label means the unit must be positioned to the left (front view).
- The RIGHT label means the unit must be positioned to the right (front view).

The control cables supplied allow a maximum distance of about 3 metres between the UPS units. This gives enough room for an external battery cabinet to be inserted beside each UPS.

2.9.3. Power connections

- The power supply to each unit must be protected as indicated in the table in paragraph 2.4.
- The cross section and length of the input and output cables must be identical for all the units.
- The phase rotation must be the same for each unit connected in parallel and also on any external manual bypass line.
- Cables of the same length and cross section must be used for the connection between the general power switch **A**, the switches **C** and the respective UPS units. The length of the cables from **A** to each UPS module must not exceed 25 metres.
- The cables from the UPS module to circuit breaker **F** must be of the same length (max. 15 metres) with multi-core cables.
- If a differential switch is installed on the mains power switch (optional), it must be inserted upstream from the distribution panel, it must be a selective type and the trigger value must be 0.5 A multiplied by the number of UPS connected in parallel.



Only activate circuit breaker D after carrying out the procedure for switching onto the maintenance bypass.



Only activate circuit breaker E after turning off the UPS.

2.9.3-1 Recommended parallel configuration

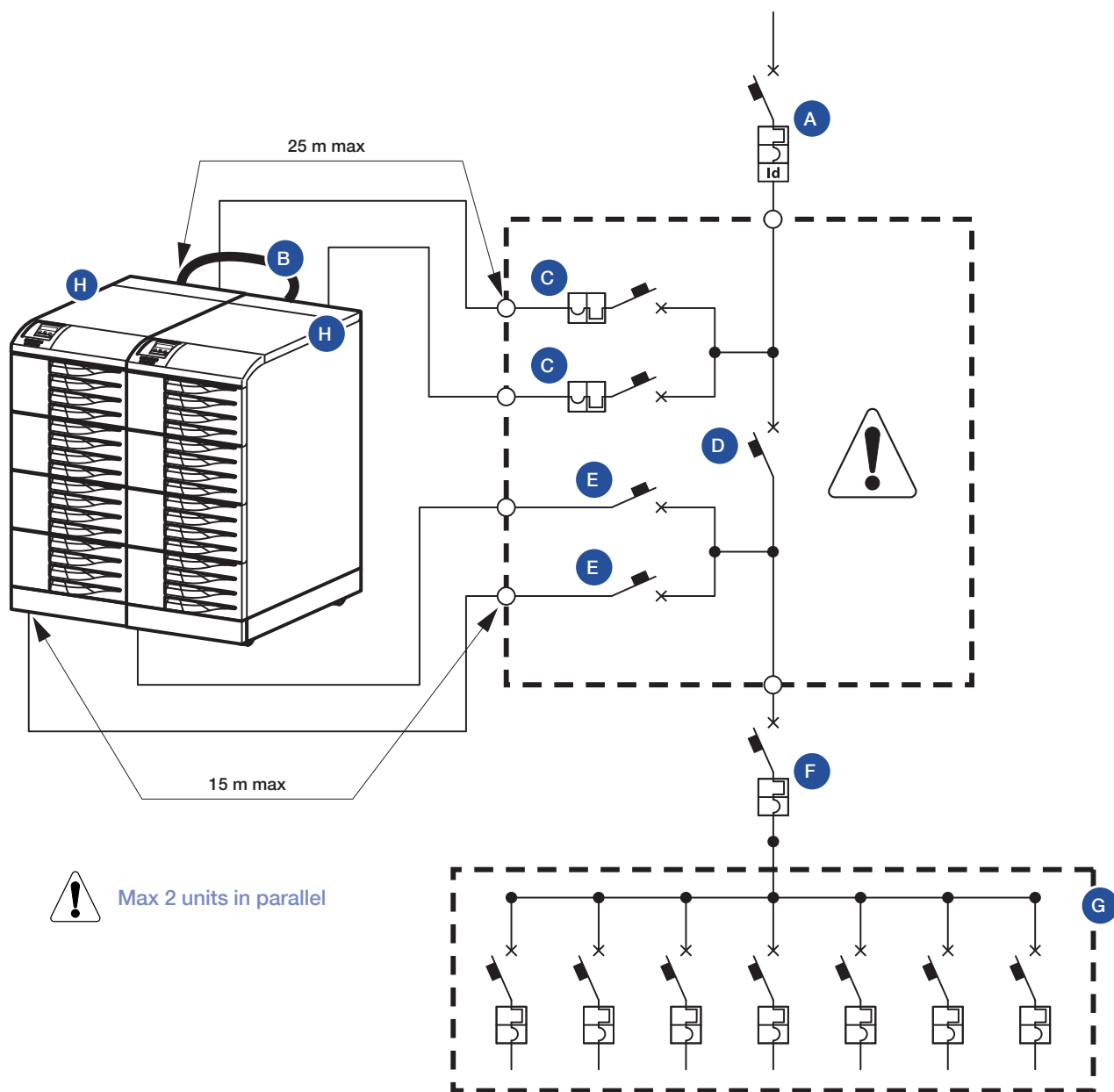

Key

- A System input switch
- B Parallel bus cable
- C Single UPS magneto-thermal switch (if a separate auxiliary power source is used, add a magneto-thermal switch for each UPS)
- D External bypass magneto-thermal switch
- E Output switch
- F System shutdown switch
- G Distribution
- H UPS

2.9.4. Control connections

In order for units connected in a parallel configuration to operate correctly, control cables are required to exchange data between the various UPS units making up the parallel system, for management of correct load sharing and synchronisation logic.

The cables in question are supplied with the UPS in the case of a standard parallel setup or are attached to the parallel kit in the case of a later system upgrade.

Parallel configuration must only be activated by SOCOMEC UPS qualified personnel; in each case arrange the control cables in the relevant cable run as shown in figure 2.9.4-1, leaving the connector(s) unconnected (in the central UPS one incoming and one outgoing control cable must be used).

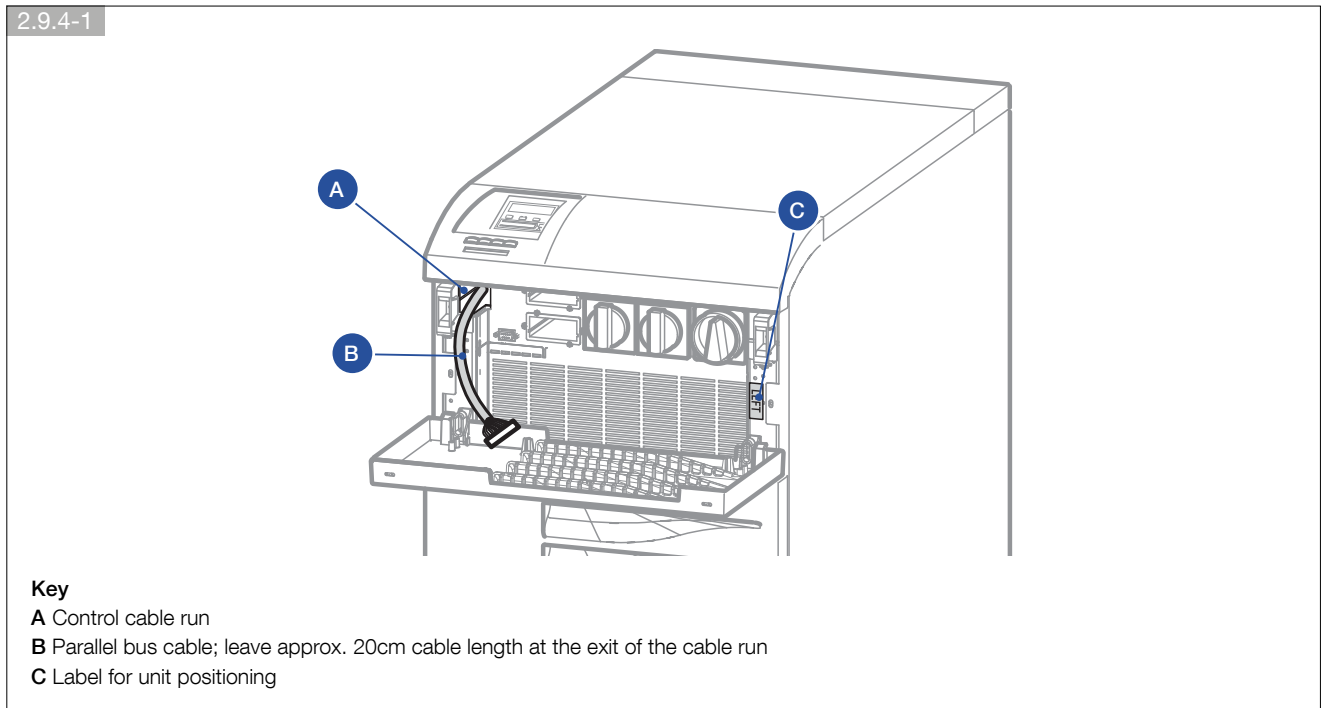

2.10. EXTERNAL BATTERY CABINET CONNECTION



If the UPS has internal batteries connecting external battery cabinets is prohibited.

Position the battery cabinet next to the UPS.



Before carrying out any operations ensure that:

- the battery fuses located inside the battery cabinet are open;
- the UPS is not live;
- all mains or battery switches are open;
- the switches upstream of the UPS are open.

- Remove the terminal board protection.
- Connect the ground cable.
- Connect the cables between the UPS terminals and the battery cabinet terminals, strictly observing the polarity of each individual string and the cross-sections indicated in table 2.4.



Use double insulated cables or the cables supplied with the unit to connect the UPS to the battery cabinet. The length L of battery cable must not be more than 8 metres long (if $L > 8$ m, please contact the support service).



Cabling errors with inversion of battery polarity may cause permanent damage to the equipment.

- Replace the terminal board's protection.



If using cabinets not supplied by the UPS manufacturer, it is the installer's responsibility to check the electrical compatibility and presence of appropriate protection devices between the UPS and the battery cabinet (fuses and switches of sufficient capacity to protect the cables from the UPS to the battery cabinet). As soon as the UPS is switched on (before closing the battery switches) the battery parameters must be verified accordingly (voltage, capacity, number of elements, etc.) on the mimic panel menu. If the values indicated on the battery cabinet data plate are different from those shown on the mimic panel use the SERVICE > CONFIGURATIONS menu to correct the settings.

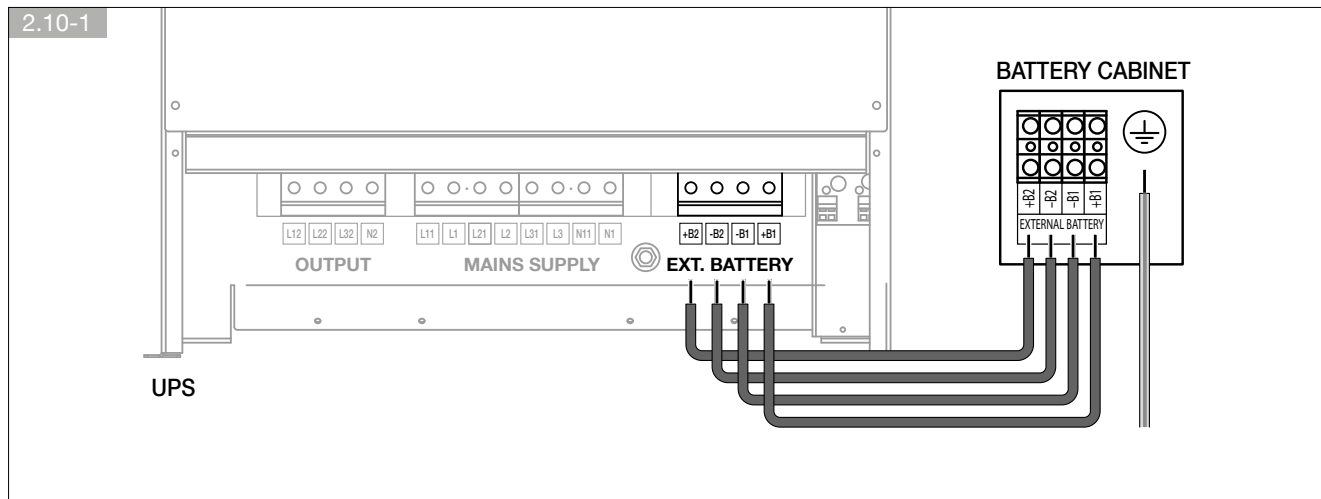

3. MODES OF OPERATION

3.1. ON LINE OPERATION

A special feature of the MASTERYS BC series is the ON LINE double conversion feature in conjunction with low distortion mains power absorption. With ON LINE mode the UPS is able to supply a voltage that is fully stabilised in frequency and amplitude, regardless of any interference in the mains power supply within the most stringent classification of UPS regulations.

ON LINE operation provides three operating modes according to mains and load conditions:

- **Normal mode**

This is the most frequent operating condition: the energy is drawn from the primary mains power supply and is converted and used by the inverter to generate the output voltage to power the loads connected.

The inverter is constantly synchronised in frequency with the auxiliary mains to enable load transfer (due to an overload or inverter shutdown) without any break in the power supply to the load.

The battery charger supplies the energy required to maintain or recharge the battery.

- **Bypass mode**

In the event of inverter failure the load is automatically transferred onto the auxiliary mains without any interruption in the power supply. This procedure may occur in the following situations:

- in the event of a temporary overload the inverter continues to power the load. If the condition persists the UPS output is switched on to the auxiliary mains via the automatic bypass. Normal operation, which is from the inverter, returns automatically a few seconds after the overload disappears.
- when the voltage generated by the inverter goes outside the limits due to a major overload or fault on the inverter.
- when the internal temperature exceeds the maximum value allowed.

- **Battery mode**

In the event of a mains failure (micro interruptions or extended power cuts), the UPS continues to power the load using the energy stored in the battery. The Expert Battery System keeps the user constantly informed on battery status and the back-up time available.

3.2. OPERATION IN HIGH EFFICIENCY MODE

The UPS allows the selection of a programmable 'economy' operating mode that can increase overall efficiency by up to 98% for energy saving purposes. With this mode of operation, specific daily or weekly time intervals can be selected and programmed to power the applications directly from the auxiliary mains. If the power supply fails the UPS will automatically switch onto the inverter and continue to supply power to the load by drawing energy from the battery.

This mode does not provide perfect stability in frequency and voltage like the ON LINE mode. Thus the use of this mode should be carefully evaluated according to the level of protection required by the application.

The Eco Mode operation provides very high efficiency, since the application is powered directly from the auxiliary mains via the automatic bypass in normal operating conditions.

3.3. OPERATION WITH MANUAL MAINTENANCE BYPASS

If the maintenance bypass is activated using the appropriate procedure the load is powered directly from the maintenance bypass, while the UPS is separated from the power supply and can be switched off.

This operating mode can be selected for maintenance to be carried out on the system so that the necessary actions can be performed by service personnel without having to disconnect the power supply to the load.

3.4. OPERATION WITH EXTERNAL MANUAL BYPASS

The external maintenance bypass may be placed on the general distribution panel when the UPS is installed, or by installing the bypass panel that is supplied on request.

If the UPS has an input for the auxiliary power supply the **Q2** switch must be connected to this input and the main power supply input must be disconnected on the control panel.

If the maintenance bypass is activated with the appropriate procedure the load is powered directly from the maintenance bypass, while the UPS is separated from the power supply and can be switched off.

This operating mode can be selected for maintenance to be carried out on the system so that the necessary actions can be performed.

Bypass panel connection diagram

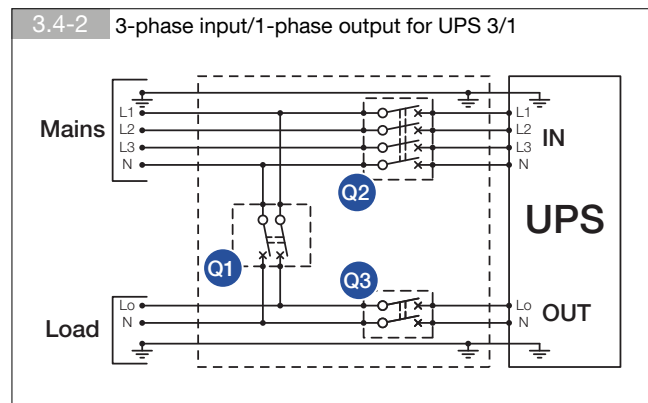
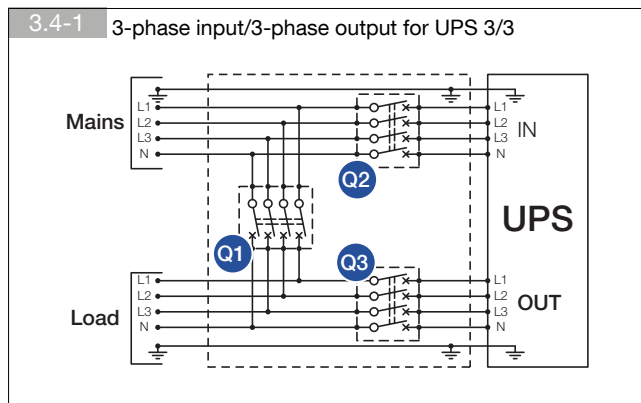

Key

- Q1 Bypass switch
- Q2 Mains power switch
- Q3 Output switch

4. ACCESS TO CONTROLS

This chapter identifies the electromechanical switches, described below, used for start-up, shutdown and maintenance bypass procedures.

Access to the control area is from the front by opening the upper door using the red handle as shown in figure 4-1. The control area also contains the communication interface connectors and the slots for the optional signalling cards. Please refer to the relevant chapter for more details on the connection and use of the relevant communication interfaces/cards.

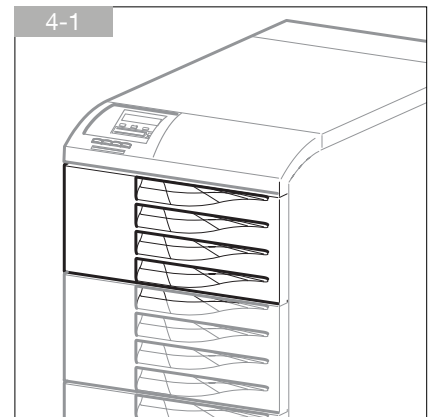

4.1. IDENTIFYING SWITCHES AND INTERFACES

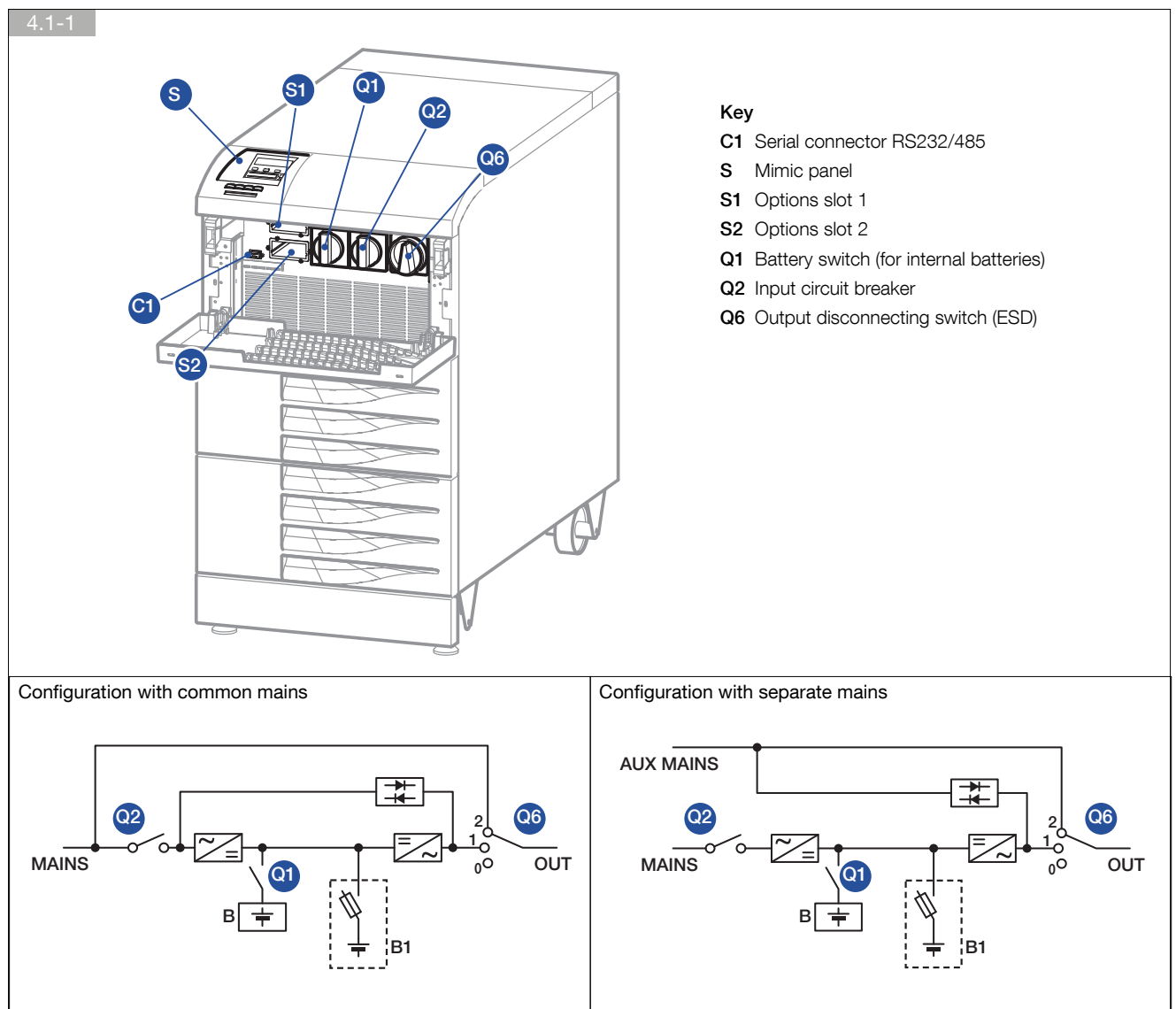

4.2. SWITCH FUNCTIONS

Input switch Q2

The input switch provides the primary power supply to the UPS.

In normal operating conditions it should be in position **1 ON**.

The position **0 OFF** will cause the batteries to discharge.

In a configuration with separate mains the switch only interrupts the rectifier power supply.

Output disconnecting switch Q6

The disconnecting switch **Q6** has three positions with the following functions:

- **Position 1 UPS:** this is the position for normal UPS operation for a continuous power supply to the load;
- **Position 2 MANUAL BYPASS:** This position should only be selected for standard or special maintenance operations (manual bypass); the load is connected directly to the mains power supply. It may be used in the event of a UPS failure to power applications from the auxiliary mains while awaiting the intervention of technical personnel;
- **Position 0 OFF:** This completely isolates the UPS output by removing the voltage from the applications in any operating conditions. It is used for the emergency shutdown of the system (internal ESD).

Battery switch Q1 (UPS batteries)

When closed, this switch connects the UPS batteries to the DC/DC converter stage to power the inverter in the event of a mains failure. The normal operating position is **1** (closed).

5. MIMIC PANEL

5.1. BASIC MIMIC PANEL

The LCD mimic panel (figure 5.1-1) located on the upper part of the UPS provides all the information on operating status, electrical measurements, access to controls and configuration parameters.

The information is grouped into four sections:

- A. LEDs that identify the subsets and the energy flow;
- B. Multicoloured light bar that identifies the condition of the power supply to the load;
- C. Alphanumeric information that uses a menu layout to provide details on any alarms that may occur and on the measurements, controls and parameters.
- D. Use of the buttons:
 - **ESC**: exit from the current menu/parameter/action;
 - **^**: scrolls the available menus/values upwards. It increases the value each time it is pressed when changing a parameter;
 - **∨**: scrolls the available menus/values downwards. It decreases the value each time it is pressed when changing a parameter;
 - **ENTER**: enters the menu displayed on the screen to confirm the choice/changes made.

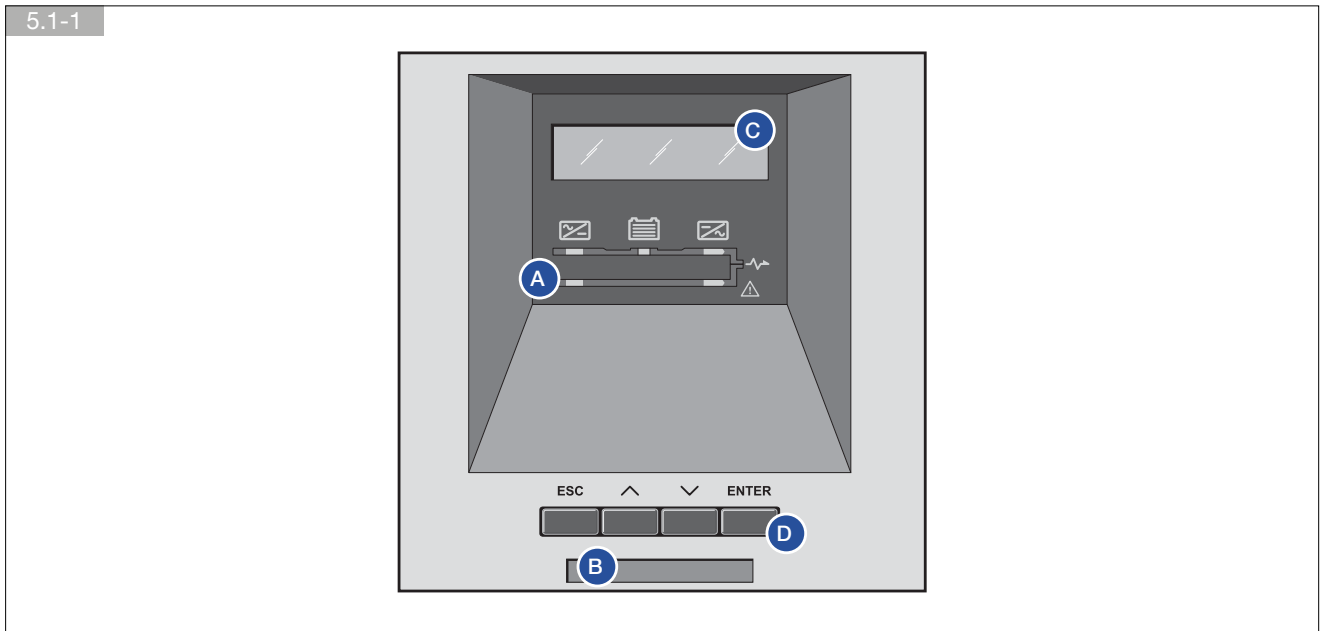

5.1.1. Meaning of LEDs

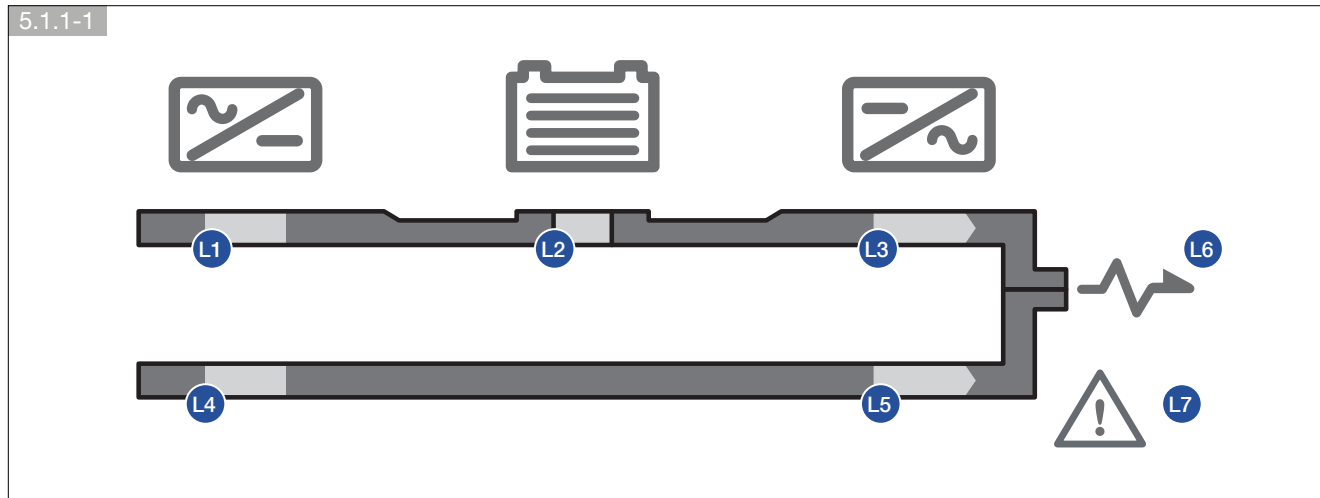

| Meaning of LEDs | | | | | | | |
|-----------------|----------------------------------|-------------------------------------|--|--|---------------------------------|--|-----------------------------------|
| LED | L1 | L2 | L3 | L4 | L5 | L6 | L7 |
| COLOUR | GREEN | YELLOW | GREEN | GREEN | YELLOW | GREEN | RED |
| ON | Rectifier and Battery charger on | Operation from battery-battery test | Inverter on | Auxiliary input mains present and Ok | Output on automatic bypass mode | Output powered | Activation code alarm-Maintenance |
| FLASHING | Rectifier alarm | Battery section alarm | Inverter failure or fault | Auxiliary input mains out of tolerance | General bypass alarm | Bypass general alarm Inverter failure or fault | General alarm |
| OFF | No input mains present | Battery charged | Inverter off or power supply from automatic bypass | Auxiliary input mains not present | Power supply from inverter | Load not powered | No alarms |

5.1.2. Meaning of light bar status

The light bar **B** (figure 5.1-1) provides immediate indication of the condition of the power supply to the load:

- Red: power supply not present or shutdown imminent.
- Yellow: power supply present but unstable or temporary.
- Green: power supply stable and regular.

| Meaning of light bar status | |
|-----------------------------|--|
| Colour | Condition displayed |
| RED flashing | Imminent shutdown alarm (the load will be disconnected in a few minutes) |
| RED | Load not powered or battery circuit open |
| YELLOW flashing | Alarm requesting standard maintenance after over 25,000-30,000 hours of operation according to conditions of use (type of load, temperature), (L7 flashing and alarm A44) UPS on standby |
| YELLOW | Load on battery or battery discharging if LED 2 is on continuously |
| YELLOW | On automatic bypass if LED 5 is on continuously |
| YELLOW | End of first maintenance period (10,000 hours) UPS in maintenance mode |
| GREEN flashing | Battery Test in progress |
| GREEN | Load powered by the inverter or in high efficiency mode |

5.1.3. Display menu

This paragraph describes the menus available on the mimic panel and their functions.

The displays are organised into menus and submenus as shown in the diagram:

- to access a menu press the **ENTER** key
- to return to the higher level press **ESC** key
- Use the **^** and **v** keys to scroll the information available at a particular level.

| FIRST LEVEL | SECOND LEVEL | THIRD LEVEL | |
|-------------|--------------|-------------|--------------------|
| MAIN | ALARMS | | |
| | MEASUREMENTS | | |
| | COMMANDS | | IMMEDIATE COMMANDS |
| | | | EXTENDED COMMANDS |
| | PARAMETERS | | UPS CURRENT DATA |
| | SERVICE | | UPS SETTING |
| | | | CIM ALARMS CODE |
| | | | WARRANTY CODE |

5.1.4. Alarms menu

This menu displays all alarms that are active at the time of access. The alarms menu is activated automatically when an alarm condition occurs.

| ALARMS menu | | |
|-------------|---------------------|---|
| Code | MIMIC PANEL MESSAGE | Description |
| A00 | GENERAL ALARM | At least one alarm is present |
| A01 | BATTERY ALARM | Battery circuit failure or faulty operation |
| A02 | OUT OVERLOAD | Power required in output over the limits |
| A06 | VAUX OUT OF TOL | The voltage or frequency limits accepted by the bypass have been exceeded |
| A07 | OVER TEMPERATURE | Temperature excessive or ventilation problems |
| A08 | MAINTEN. BYPASS | Active bypass procedure |
| A17 | IMPROPER USE | Improper conditions of use verified (load, mains, temperature) |
| A18 | OVERLOAD OFF INV | Inverter shutdown due to overload |
| A20 | WRONG CONFIG. | Error in the configuration parameters (e.g. different between several UPS units in parallel) |
| A22 | MAINS OUT OF TOL | The voltage or frequency limits accepted by the rectifier have been exceeded |
| A23 | RECTIFIER ALARM | Rectifier fault |
| A25 | INVERTER ALARM | Inverter fault |
| A26 | BATT CHARGER ALM | Battery charger fault |
| A29 | BYPASS ALARM | Bypass fault |
| A30 | OVERLOAD STOP | The duration of the overload has inhibited the bypass |
| A38 | EXTERNAL ALARM1 | Signalling from ADC input |
| A39 | EXTERNAL ALARM2 | Signalling from ADC input |
| A40 | EXTERNAL ALARM3 | Signalling from ADC input |
| A41 | EXTERNAL ALARM4 | Signalling from ADC input |
| A42 | T-SERVICE ALARM | Alarm that automatically sends a signal to the support centre (if the service has been activated) |
| A43 | REDUNDANCY LOST | The power required by the load no longer allows the preset redundancy N+x (signalling for UPS units in parallel) to be maintained |
| A44 | SERVICE CHECK | Notification that the routine service check is overdue |
| A49 | BATT. DISCHARGED | The energy available in the battery has been depleted |
| A51 | OPT. BOARD ALM | Fault in the optional cards in the slots |
| A58 | ESD ACTIVATED | The remote emergency shutdown command has been activated |
| A59 | BATT.CIRC. OPEN | The battery switch is open |
| A60 | FAN FAILURE | Fans faulty or blocked |
| A61 | PHASE ROT. FAULT | Wrong phase cycle direction |

5.1.5. Measurements menu

This menu is used to display all measurements relating to UPS input, output, and the battery. For models with single phase input or output, the voltage and current displays are adjusted automatically.

| MEASUREMENTS menu | | | | |
|----------------------|---------|---------|-------|---|
| Type of measurements | Value | Value | Value | Note |
| OUTPUT VOLTAGE | ___ V | ___ V | ___ V | Output voltage |
| OUTPUT LOAD | __ % | __ % | __ % | Output load percentage |
| OUT ACTIVE PWR | __._ kW | | | Output active power |
| OUTPUT FREQUENCY | __._ Hz | | | Output frequency |
| AUX VOLTAGE | ___ V | ___ V | ___ V | Auxiliary mains voltage |
| AUX FREQUENCY | __._ Hz | | | Auxiliary mains frequency |
| INPUT VOLTAGE | ___ V | ___ V | ___ V | Input mains voltage |
| INPUT FREQUENCY | __._ Hz | | | Input mains frequency |
| BATTERY VOLTAGE | B+___ V | B+___ V | | Battery voltage |
| CAPACITY | __ % | | | Battery capacity percentage during charging |
| BACKUP INFO | T__MIN | | | Backup time during battery discharge |
| INTERNAL TEMP. | __ °C | | | Internal temperature |

5.1.6. Commands menu

This is used to send immediate commands for start-up/shutdown/reset alarms to the UPS and to select the operating mode. Commands can also be sent for diagnostic purposes by means of the extended commands menu (if enabled in the configurations menu). The command is activated by selecting it with the \wedge and \vee keys, press **ENTER**, confirm **YES** or **NO**, then press **ENTER**.

| IMMEDIATE COMMANDS menu | |
|-------------------------|---|
| Command | Description |
| START PROCEDURE | UPS start-up command |
| STOP PROCEDURE | UPS shutdown command |
| HIGH EFF. MODE | High efficiency mode: activates the energy saving feature |
| NORMAL MODE | Activates normal double conversion operation |
| ALARMS RESET | Resets all the alarms |
| LEDS TEST | Performs test on mimic panel LEDs |

| EXTENDED COMMANDS menu | |
|------------------------|--|
| Command | Description |
| BATTERY TEST | Activates the battery test to check battery efficiency |
| BATT.COMMISSION | Activates forming charging for the battery |
| CHECK-UP DISAB. | Disables the regular maintenance message |

5.1.7. Parameters menu

Displays the UPS parameters set.

| UPS CURRENT DATA menu | |
|--|---|
| Message | Description |
| MASTERY'S 3/3 30 KVA SN. 0000000000 | Displays the size, input and output phase configuration and UPS serial number |
| UC FW. REVISION RV 000 CKS: 0000 | Identifies the microprocessor software release |
| DSP FW. REVISION RV 000 CKS: 0000 | Identifies DSP software release |

5.1.8. Service menu

This is used to change the configuration parameters, insert the warranty activation code and display the service code.

UPS SETTINGS menu

This is used to change the configuration parameters. Access is via the password **MAST** which is keyed in by using the \wedge and \checkmark keys and **ENTER** to go on to the next letter.

| UPS SETTINGS menu | | |
|------------------------|---|---|
| Parameter | Description | Allowed values |
| SET LANGUAGE | Sets the required language | English, Français, Italiano, Deutsch, Español |
| SET OUTPUT VOLTAGE | Sets the required output voltage value | 208/220/230/240 V |
| SET OUTPUT FREQUENCY | Sets the required output frequency value | 50/60 Hz |
| SET MODE CONVERTER | Sets whether or not the UPS has to operate as a frequency converter  WARNING! Set only on UPS with mains power (MAINS) and auxiliary mains (AUX MAINS) separated and with the auxiliary mains (AUX MAINS) disconnected! Do not set on UPS with common mains lines as it could damage the load! | YES/NO |
| SET MODE AUTORESTART | Sets whether or not the UPS has to restart automatically after shutdown due to minimum battery | YES/NO |
| SET BATTERY AVAILABLE | Set if battery is present | YES/NO |
| if YES: | | |
| - SET BATTERY TYPE | Selects the type of batteries used | Sealed |
| - SET BATTERY CAPACITY | Sets the battery capacity in Ah | 9.5 – 1000 Ah |
| - SET CHARGER TYPE | Selects the type of recharge required | Auto, Float, int. |
| - SET BATTERY ELEMENTS | Set the number of battery elements | 108-144 |
| - SET BATT_TEST PERIOD | Sets the frequency rate of the battery test in days | 0, 30, 60, 90, 120,150,180 (zero do not perform the test) in days |
| SET BACKFEED | Sets the type of backfeed protection | Disable, 2.ByPass-Input alone, 3.ByPass-Input common |
| SERIAL LINK | Inserts the serial communication parameters: - Serial Link Baud Rate - Serial Link Parity - Serial Link Bit Number - Serial Link Stop Bits When the data is confirmed, the serial connection automatically changes the configuration without having to switch off the UPS. | 1200/2400/4800/9600/14.4 odd/even/none 8-9 0-1 |
| JBUS SETTING SLAVE NR. | Sets the mimic panel jbus node When the data is confirmed, the serial connection automatically changes the configuration without having to switch off the UPS. | 1/32 |
| DATE SETUP | Sets the date | DD/MM/YY |
| TIME SETUP | Sets the time | HH:MM |
| SYN EXT CMDS ENABLED | Enables/Disables the mimic panel extended commands | YES/NO |
| REMOTE CMDS ENABLED | Enables the transmission of commands from external systems | YES/NO |
| SET BUZZER ENABLED | Enables/Disables the buzzer | YES/NO |

CIM Alarms Code menu

This displays the service code to be sent to the support service to make an accurate and rapid diagnosis of the possible failure. In the event of a fault, select the menu **SERVICE > CIM ALARMS CODE** and inform the support centre of the code displayed.

```
ALARMS CODE 1/2
1) 0000 2) 0000
```

```
ALARMS CODE 2/2
3) 0000 4) 0000
```

Warranty Code menu

During equipment commissioning, a warranty activation code, comprising four characters, is required to complete the start-up procedure.

```
5.3 WARRANTY CODE
COMMISSIONING
```

The activation code is provided directly by the reference Support Centre upon communication of the equipment serial number which is displayed in the next message by pressing **ENTER**.

```
WARRANTY CODE
SN: 0000000000
```

Inserting the code does not limit the availability of equipment functionality.

When the Support Centre is contacted for the activation code, detailed information can be obtained on the UPS functions available and regular routine maintenance programmes.

Once the code is obtained, enter it by pressing **ENTER** to activate the entry (two asterisks will appear). Select the first character with the **^** and **v** keys and confirm with **ENTER** to accept the character. Then move on to the next character. Pressing the **ENTER** key after selecting the fourth character activates the code.

```
WARRANTY CODE
CODE - - - -
```

An error message is displayed if the code is incorrect. Check that the code displayed corresponds to the code provided by the Support Centre and repeat the procedure.

6. OPERATING PROCEDURES

This chapter defines the operating procedures to be followed to activate and manage the UPS.



For UPS units in parallel.
Carry out the procedures on all UPS units before going on to the next operation.
Each procedure should be carried out on all UPS units within 30 seconds.

6.1. START-UP IN NORMAL MODE

- Set switch **Q1** and/or the external batteries switches to position **1** (battery circuit closed).
- Apply voltage to the UPS.
- Set switch **Q2** to position **1** (input mains ON).
- Wait for the mimic panel to start up.
- Activate the **START PROCEDURE** from the **COMMANDS** menu on the mimic panel.
- Set disconnecting switch **Q6** to position **1** (continuous output).
- The load is now powered and protected by the UPS.

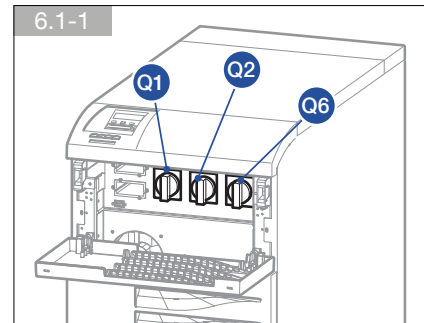

6.2. SHUTDOWN

Shutdown interrupts the power supply to the load and stops the UPS and the battery charger.

- Activate the **STOP PROCEDURE** from the **COMMANDS** menu on the mimic panel, wait approx. 2 minutes for shutdown (the controlled shutdown of any servers is managed via the shutdown software).
- Set disconnecting switch **Q6** to position **0** (inverter in output OFF).
- Set switch **Q1** and/or battery switches to position **0** (battery circuit open).
- Set switch **Q2** to position **0** (input mains OFF).

6.3. EXTENDED OUT OF SERVICE

In the event of an extended period of UPS inactivity, the batteries must be recharged every three months.

- Set switch **Q1** and/or the external battery switches to position **1** (battery circuit closed).
- Apply voltage to the UPS.
- Set switch **Q2** to position **1** (input mains ON).
- Set or keep disconnecting switch **Q6** to position **0** (inverter in output OFF).
- The battery must be charged for at least ten hours.
- After ten hours:
 - Set switch **Q1** and/or battery switches to position **0** (battery circuit open).
 - Set switch **Q2** to position **0** (input mains OFF).
- The UPS can be switched off.

6.4. SWITCHING ONTO MANUAL BYPASS

Switching onto manual bypass creates a direct connection between the UPS input and output, completely excluding the equipment control element.

This operation is performed in the event of standard maintenance on the equipment, so as not to remove the power supply from the load, or in the event of a serious failure while waiting for the equipment to be repaired.

- From the mimic panel set the **HIGH EFF. MODE** command from the **IMMEDIATE COMMANDS** menu.
- Wait for the command to be executed (bypass line on the M1 display on). If this does not take place, suspend the operation (the auxiliary mains is not suitable for the load).
- Set disconnecting switch **Q6** to position **2**.
- Set switch **Q1** and/or battery switches to position **0** (battery circuit open).
- Open the switch **Q2**.



If there is an external manual bypass carry out the procedure described above before activating this switch.

6.4.1. Return to normal mode

- Set switch **Q2** to position **1** (input mains ON).
- Set switch **Q1** and/or the external battery switches to position **1** (battery circuit closed).
- Activate the start procedure from the commands menu on the mimic panel.
- From the mimic panel set the **HIGH EFF. MODE** command from the **IMMEDIATE COMMANDS** menu.
- Check that alarm A06 is not present (if the alarm is present, resolve the problem before continuing).
- Set disconnecting switch **Q6** to position **1** (inverter in output ON).



If there is an external manual bypass, put the switch to position OFF.

- From the mimic panel set the **NORMAL MODE** command from the **IMMEDIATE COMMANDS** menu.

6.5. EMERGENCY SHUTDOWN (ESD)

Should it be necessary to interrupt the continuous power supply provided by the UPS quickly (emergency shutdown), this can be done by putting disconnecting switch **Q6** to position **0** (zero) or, where applicable, by activating the emergency button/switch connected to the ADC PCB.



The UPS output can only be electrically disconnected by means of Q6.

If the UPS is operating from the manual bypass with mains present, shutdown using the emergency button does not interrupt the power supply to the load. In emergency conditions all the power supply sources upstream of the UPS must be disconnected.

7. CONNECTIVITY AND COMMUNICATION OPTIONS

7.1. MULTI-LEVEL COMMUNICATION

MASTERYS BC can manage a variety of serial, contact and Ethernet communication channels simultaneously.

The various cards and signalling accessories are inserted in the two standard communication slots. This gives MASTERYS BC immediate interfacing and integration flexibility as soon as the unit is installed with no need for trained personnel.

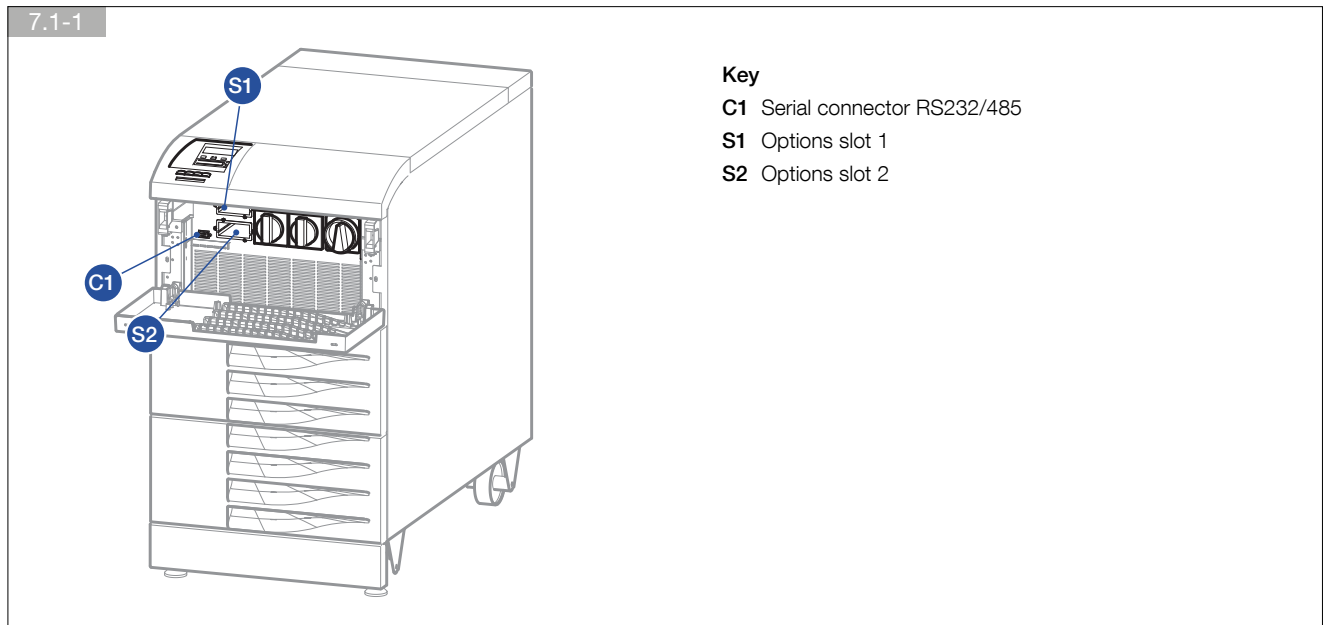

As each channel is independent, simultaneous connections can be made to satisfy the different levels of signalling and remote monitoring.

See the operating procedures paragraph to access the detailed functions of the cards installed in the slots.

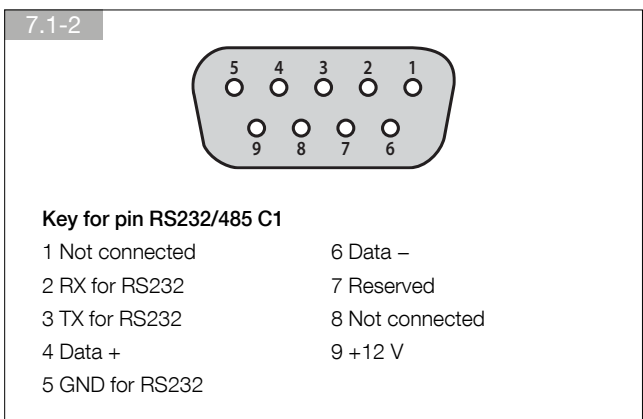

7.2. ADC CARD / ADC CARD WITH TEMPERATURE SENSOR

To be installed in one of the two slots available, these cards can be used to manage up to four normally closed or normally open outputs, and up to three digital inputs in configurable mode. If more than one ADC card is used simultaneously, the dip switch configurations must be different. Secure the card with the appropriate screws.

This card can be configured to control up to four outputs that can be set as normally closed or normally open and up to three digital inputs. The card is inserted in one of two slots provided. Up to four operating modes can be selected using the two DIP switches 1 or 2.

• Electrical data

- Permitted Nominal current and voltage of NO or NC contacts: 2 A 250 Vac depending on the terminal used.
- Inputs are activated on loop closing.

• Connection of the generator

If your system uses a generator connect the ‘generator set ready’ no-potential contact to connector IN 2 on the optional ADC card configured in standard or power safe mode. This automatically extends the voltage and frequency value range when power is supplied by the generator set.

• External ESD connection

A remote emergency shutdown system (ESD) can be installed by means of the optional ADC card. Connect a normally closed zero-potential contact to terminals IN1+ and IN1- of the ADC card.

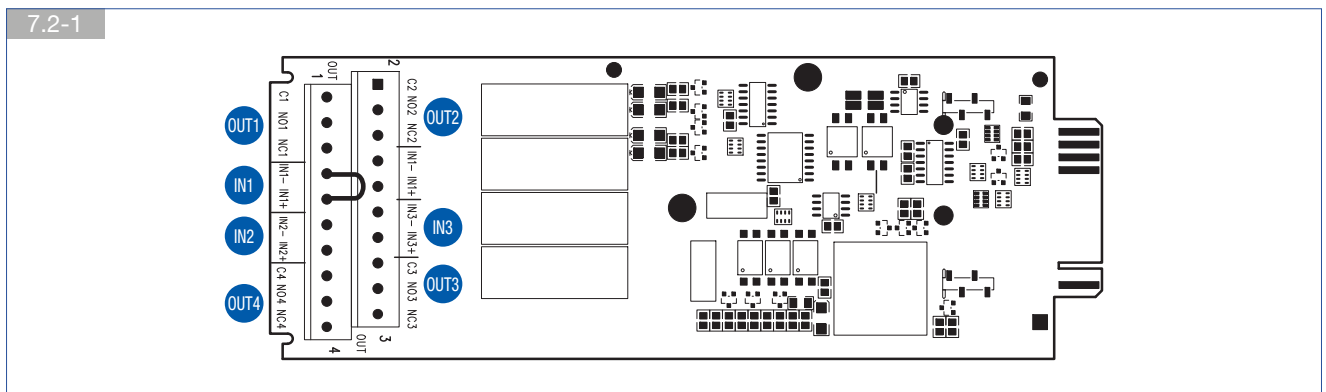

The filter level indicates the activation delay: 1 immediate activation (1 second minimum communication time), 2 10 s delay, 3 30 s delay.

| STANDARD configuration (default) DIP1: OFF - DIP2: OFF | | |
|---|------------------------------|--------------|
| IN/OUT | Description | Filter level |
| OUT 1 | General alarm | 2 |
| OUT 2 | Battery discharging | 3 |
| OUT 3 | Battery low or imminent stop | 2 |
| OUT 4 | UPS on bypass | 2 |
| IN 1 ⁽¹⁾ | ESD | 1 |
| IN 2 | Supply from GenSet | 1 |
| IN 3 | Insulation controller | 2 |

| POWER SAFE configuration DIP1: ON - DIP2: OFF | | |
|--|----------------------------------|--------------|
| IN/OUT | Description | Filter level |
| OUT 1 | General Alarm | 2 |
| OUT 2 | Power safe plug 1 | 2 |
| OUT 3 | Power safe plug 2 | 2 |
| OUT 4 | Power safe plug 3 | 2 |
| IN 1 ⁽¹⁾ | ESD | 1 |
| IN 2 | Supply from GenSet | 1 |
| IN 3 | Management of energy consumption | 1 |

| SAFETY configuration DIP1: OFF - DIP2: ON | | |
|--|------------------------------|--------------|
| IN/OUT | Description | Filter level |
| OUT 1 | General Alarm | 2 |
| OUT 2 | ESD activation | 1 |
| OUT 3 | Battery low or imminent stop | 2 |
| OUT 4 | ESD activation | 1 |
| IN 1 ⁽¹⁾ | ESD | 1 |
| IN 2 | External alarm A39 | 2 |
| IN 3 | External alarm A40 | 2 |

| ENVIRONMENTAL configuration DIP1: ON - DIP2: ON | | |
|--|-------------------------------|--------------|
| IN/OUT | Description | Filter level |
| OUT 1 | General Alarm | 2 |
| OUT 2 | Overheating | 2 |
| OUT 3 | Overload / Loss of redundancy | 2 |
| OUT 4 | External alarm In2 | 2 |
| IN 1 ⁽¹⁾ | ESD | 1 |
| IN 2 | External alarm A39 | 2 |
| IN 3 | External alarm A40 | 2 |

(1) If the external ESD button is not used always insert a jumper to short circuit input IN 1

| Description of signals | |
|----------------------------------|--|
| Message on the mimic panel | Description |
| General Alarm | 'General Alarm' contact output No alarm 'General Alarm' active  |
| Battery Low or Imminent stop | Battery low voltage and imminent shutdown contact output |
| Supply from GenSet | Generator ready signal input |
| Power safe plug 1 | Non privileged load 1 command output activated by overload or loss of redundancy |
| Power safe plug 2 | Non privileged load 1 command output activated by battery discharging |
| Power safe plug 3 | Non privileged load 1 command output activated by low battery |
| Management of energy consumption | Input for the battery to help providing energy in the event of peak consumption |
| ESD activation | Shutdown for ESD contact output |
| Overheating | Internal overheating contact output |
| Overload/Loss of redundancy | Overload / loss of redundancy contact output |



Intervention of the ESD input switches off the UPS output.

To restore the UPS to operation:

- Close the ESD contact on 'In 1' on the ADC board.
- Send the Alarms Reset command.
- Run the Automatic Start Procedure

7.3. REMOTE MIMIC PANEL

This device monitors and interacts with the UPS through a serial link RS 485 (maximum distance of 175 m) 25 m cable supplied as standard and 50 m cable available as an option.

7.4. NET VISION LAN/WEB INTERFACE

NET VISION is a communication and management interface to be installed in the UPS slot designed for business networks. The UPS behaves exactly like a networked peripheral, it can be managed remotely and allows the shutdown of network workstations.

NET VISION allows a direct interface between the UPS and LAN network avoiding dependence on the server and support SMTP, SNMP, DMCP and many other protocols. It interacts via the Web browser.



Please note that two Net Vision cards cannot be connected simultaneously.

7.5. PROFIBUS INTERFACE

The externally mounted PROFIBUS adapter allows UPS models to be connected to a Profibus network.

7.6. SOFTWARE OPTIONS

A large number of SW solutions can be adopted on MASTERYS BC thanks to its advanced communication facilities. These solutions have been specially designed for the efficient management of power protection devices.

Visit www.socomec.com and click on **DOWNLOAD** then **SOFTWARE** to find the communication software which is suitable for your requirements.

8. TROUBLESHOOTING

The alarm messages displayed enable immediate diagnosis.

Alarms are divided into two categories:

- alarms related to the UPS external circuits, (input mains, output mains, temperature and environment).
- alarms related to the UPS internal circuits. In this case, corrective actions will be carried out by the After Sales Department.

8.1. SYSTEM ALARMS

• A02: OUT OVERLOAD

The power required by the loads is higher than the power available.

Check that the load is well balanced on the three phases by checking the measurements on the display. If necessary disconnect any loads that do not need uninterruptible power.



Important!

The accepted overload time limit is defined in the technical specifications. When this time limit is exceeded the loads will no longer be powered by the inverter.

• A06: VAUX OUT OF TOL

The auxiliary mains supply exceeds the acceptable tolerance values. Possible causes are:

- No voltage or frequency present or voltage and frequency outside acceptable values (see the technical specifications).
- The frequency is subject to continuous variations (typical with power supplied from an incorrectly sized GE).

• A07: OVER TEMPERATURE

The technical plant temperature is higher than the maximum value recommended.

Check the ventilation or air conditioning system in the UPS room.

• A08: MAINTEN. BYPASS

The output disconnecting switch Q6 is in position 2 (maintenance bypass). The load is therefore powered directly by mains power supply.

• A17: IMPROPER USE

This alarm does not indicate a malfunction or failure of the UPS, but an incorrect use/sizing of the system. It is activated in the event of:

- Operation for long periods at high temperatures (battery deterioration)
- High number of overloads (wrong sizing)
- Continuous battery discharging (mains not stable)
- High number of switches onto the bypass (high impulsive loads).

• A22: MAINS OUT OF TOL

The input mains is not present or not sufficient (voltage and/or frequency values incorrect with reference to the technical data); if there is no input mains outage check that no protection devices upstream of the UPS have tripped.

Check the voltage applied and frequency values are in compliance with the values set on the mimic panel.

• A38, A39, A40, A41: EXTERNAL ALARM 1, 2, 3, 4

One of the ADC card inputs has been activated; check the status of the devices connected to this card.

• A61: PHASE ROT. FAULT

The phase cycle sequence is incorrect. In this case invert two phases of the input mains. For a UPS with separate auxiliary mains exchange the two phases of the auxiliary mains only.

8.2. UPS ALARMS

- **A01: BATTERY ALARM**

Failure or problem on the battery circuit. Check the battery switch is closed.

- **A18: OVERLOAD OFF INV**

Reduce the load rate applied to the UPS and reset the alarms.

- **A20: WRONG CONFIG.**

Error in the configuration parameters; contact the support service.

- **A30: OVERLOAD STOP**

Reduce the load rate applied to the UPS and reset the alarms.

- **A42: T-SERVICE ALARM**

MASTERY'S BC products can be remotely serviced. This alarm indicates that a procedure to analyse the UPS failure has been activated by the support centre (if an e-service contract has been agreed).

- **A44: SERVICE CHECK**

The equipment has to undergo regular checks by the support service in order to ensure optimum performance and efficiency. If the Scheduled Inspection signal appears on the mimic panel, the equipment should be inspected by a suitably trained technician.

- **A59: BATT.CIRC. OPEN**

Battery switch open.

- **A60: FAN FAILURE**

Fault in the ventilation system; check the air inlet at the front and the air outlet at the back of the UPS are not obstructed.

8.3. PREVENTIVE MAINTENANCE

Please note that specialist regular maintenance (annually) is recommended for the MASTERY'S BC to provide optimum operating efficiency and avoid equipment downtime.

It is strongly advisable to give due consideration to any instructions to perform preventive maintenance displayed automatically with alarm message M29 (refer to paragraph 6.2.3.1).

All operations on the equipment must only be carried out by SOCOMEC UPS personnel or authorised support personnel.

Maintenance consists of accurate functional checks on electronic and mechanical parts with replacement of parts subject to wear if necessary (typically batteries, fans and capacitors).

8.3.1. Batteries

The condition of the battery is fundamental to UPS operation.

Thanks to the Expert Battery System, the information relating to the battery status and conditions of use are processed in real time and recharging and discharging procedures are selected automatically in order to optimise battery life expectancy and offer maximum performance.

Furthermore, during the operating life of the battery, MASTERY'S BC stores statistics on the conditions of use of the battery for analysis.

Since the expected lifetime of the batteries is very much dependent on operating conditions (number of charging and discharging cycles, load rate, temperature), a regular check by authorised personnel is recommended.



When replacing the batteries use the same type and configuration by placing them in appropriate containers to avoid the risk of acid leakage.

Used batteries must be disposed of at authorised recycling and disposal centres.

Do not open the plastic cover of the batteries as they contain harmful substances.

8.3.2. Fans

The lifetime of the fans used to cool the power parts is dependent on usage and environmental conditions (temperature, dust). Preventive replacement by an authorised technician is recommended within four years (in normal operating conditions).



When necessary fans should be replaced as per specifications by **SOCOMECS UPS**.

8.3.3. Capacitors

The equipment houses electrolytic capacitors (used in the rectifier and inverter section) and filtering capacitors (used in the output section), the lifetime of which is dependent on usage and environmental conditions.

The average expected lifetime of these components is shown below:

- Electrolytic capacitors: 5 years;
- Filtering capacitors: 7 years.

Component status is however verified during preventive maintenance.

9. ELECTRICAL OPTIONS

9.1. INSULATION CONTROLLER

This device continually checks transformer insulation, displaying an alarm message on the mimic panel.

9.2. EXTERNAL MAINTENANCE BYPASS

This device will electrically exclude and isolate the UPS (e.g. for maintenance operations) without interrupting the power supplied to the load.

9.3. EXTERNAL MAINTENANCE BYPASS WITH BACKFEED PROTECTION

This device will electrically exclude and isolate the UPS (e.g. for maintenance operations) without interrupting the power supplied to the load. 3-pole contactors are used for backfeed protection.

Note: an additional option is available to bring the manual bypass signal back to the UPS.

9.4. ACS PCB

Synchronises UPS output with an external power source (another UPS, even of a different brand, generator or transformer).

9.5. EXTERNAL BACKFEED PROTECTION

External devices can be installed to protect against the back-feed of dangerous currents, both on the **MAINS SUPPLY** and on the **AUX MAINS SUPPLY**. These devices are controlled by the **BKF PCB** installed in the position shown in figure 9.5-1.

Refer to the following paragraphs for details on electrical connections and on activating the chosen protection.

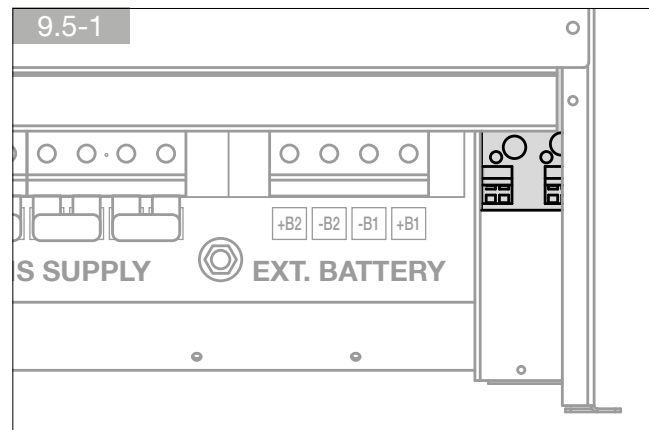

9.6. PROTECTION ON THE SEPARATE AUXILIARY MAINS

Activating UPS protection on the mimic panel: access the **UPS SETTING** menu on the mimic panel (see the **UPS SETTING** menu under the **SERVICE** menu section of the manual) and set the **SET BACKFEED** parameter to **1.BYPASS**.

Cable and trunk schematic

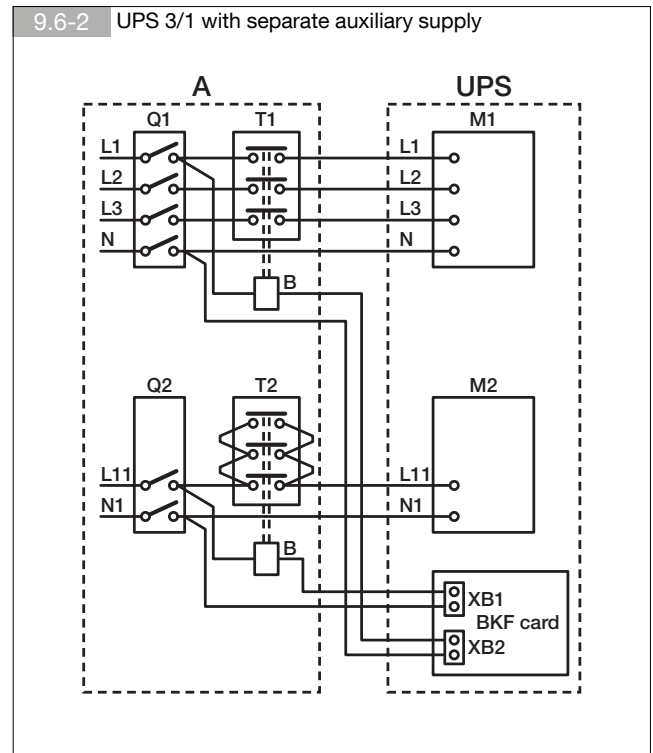
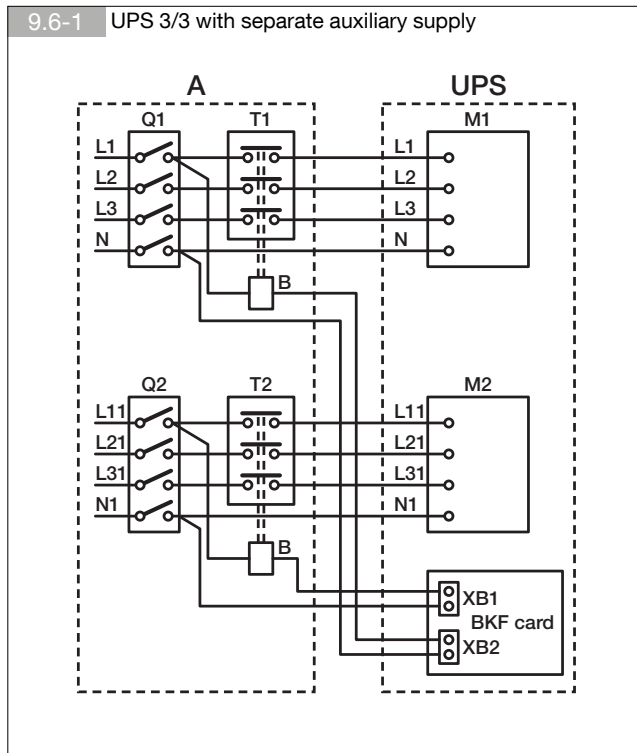

Key

- A Distribution panel
- B Remote coil switch
- L1-L2-L3-N Input power source
- L11-L21-L31-N1 Backup power source
- M1 Input power terminal board
- M2 Backup power terminal board
- T1 Remote switch¹
- T2 Remote switch¹
- Q1 Input power switch
- Q2 Backup power switch
- XB1 Connector on BKF PCB
- XB2 Connector on BKF PCB

¹Remote switches - rated current

| Model | T1 | T2 |
|--------|----------|----------|
| 15 3/1 | 32 A AC1 | 45 A AC1 |
| 15 3/1 | 32 A AC1 | 32 A AC1 |
| 20 3/1 | 45 A AC1 | 60 A AC1 |
| 20 3/3 | 45 A AC1 | 45 A AC1 |
| 30 3/3 | 60 A AC1 | 60 A AC1 |
| 40 3/3 | 90 A AC1 | 90 A AC1 |

9.7. PROTECTION ON A UPS WITHOUT AUXILIARY MAINS SUPPLY

Activating UPS protection on the mimic panel: access the **UPS SETTING** menu on the mimic panel (see the **UPS SETTING** menu under the **SERVICE** menu section of the manual) and set the **SET BACKFEED** parameter to **3.BYPASS-INPUT Common**.

Cable and trunk schematic

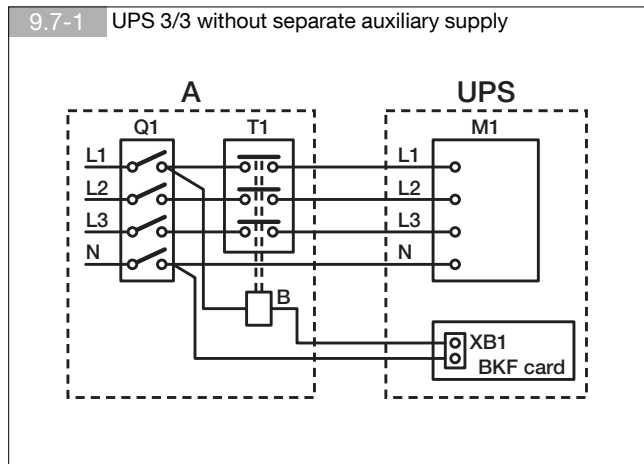

| Remote switches - rated current | |
|---------------------------------|----------|
| Model | T1 |
| 15 3/1 | 32 A AC1 |
| 15 3/3 | 32 A AC1 |
| 20 3/1 | 45 A AC1 |
| 20 3/3 | 45 A AC1 |
| 30 3/3 | 60 A AC1 |
| 40 3/3 | 90 A AC1 |

Key

- A** Distribution panel
- B** Remote coil switch
- L1-L2-L3-N** Input power source
- M1** Input power terminal board
- Q1** Input power switch
- T1** Remote switch¹
- XB1** Connector on BKF PCB

Note: The neutral is not disconnected as, even in the event of a single fault on the UPS, it never has high potential when the mains and/or auxiliary power supplies are disconnected upstream. This is to prevent transformation of the power source to the UPS every time there is a power failure.

Should the Neutral potential be very high due to certain error conditions or due to installations downstream (e.g. ground fault not detected and protected, high dispersion of a phase, or the IT system), it will be necessary to install either devices that disconnect the Neutral or alternatively a system that detects, signals and protects against high neutral/ground potential which could lead to UPS failure.

ENGLISH

10. TECHNICAL SPECIFICATIONS

| | | | | | |
|---|--|--|-------------|------------------|----------|
| Models | | 15 | 20 | 30 | 40 |
| Input/Output phases | | 3/1 and 3/3 | 3/1 and 3/3 | 3/3 | 3/3 |
| Electrical specifications - Input | | | | | |
| Mains voltage | Vin | 3Ph+N 400 V -15% +20% (up to -40% @50% of nominal load) | | | |
| Input frequency | Hz | 50-60 ±10% | | | |
| Input power factor | | > 0.99 (three phase) | | | |
| THDI | | < 3% | | | |
| Electrical specifications - External battery | | | | | |
| Battery voltage range | V bat | from +/-175 ³ up to +/-360 ⁴ Vdc | | | |
| Electrical specifications - Output | | | | | |
| Output voltage (three phase + neutral) | V | 230 single phase (selectable: 208/220/230/240 V) ±1% ¹ 400 three phase (selectable 360/380/400/415 V) ±1% ¹ | | | |
| Frequency | Hz | 50-60 ±2% (from 1% to 8% if generator is used) | | | |
| Automatic bypass | | nominal output voltage ±15% (from 10% to 20% selectable if generator is used) | | | |
| Nominal power | kW | 13,5 | 18 | 27 | 36 |
| Overload (@ 25 °C; Vin > 380; Vbat > 216) ² | <ul style="list-style-type: none"> • 10 minutes • 1 minute | 16,875 20,25 | 22,5 27 | 33,75 40,5 | 45 54 |
| Crest factor | | ≥ 2.7 | | | |
| Voltage distortion | | 1% with linear load | | | |
| Environment | | | | | |
| Operating temperature | °C | 0÷35 (15÷25 recommended for longer battery life) | | | |
| Storage temperature | °C | -5÷45 | | | |
| Relative humidity | % | 0÷95 condensation-free | | | |
| Max. altitude | m | 1.000 without derating; 3.000 max | | | |
| Acoustic noise | dBA | < 52 | < 52 | < 55 | < 55 |
| Required cooling capacity | m³/h | 280 | 280 | 465 | 465 |
| Dissipated power max | W | 883 | 1211 | 1706 | 2142 |
| Dissipated power max | BTU/h | 3016 | 4135 | 5823 | 7250 |
| Standards | | | | | |
| Safety | | EN 62040-1, EN 60950-1 | | | |
| Type and performance | | EN 62040-3 (VFI-SS-111) | | | |
| EMC | | EN 62040-2 | | | |
| Product certification | | CE - TÜV-SÜD | | | |
| Protection level | | IP20 (compliant with 60529), IP21 on request | | | |
| Mechanical characteristics with standard batteries | | | | | |
| Models | T | Dimensions | mm | 444 x 795 x 1400 | |
| | | Weight | kg | 390÷540 | |
| | M | Dimensions | mm | 444 x 795 x 1000 | |
| | | Weight | kg | 230÷315 | |
| | S | Dimensions | mm | 444 x 795 x 800 | |
| | | Weight | kg | 190÷200 | |

1. 360 V with Pout = 90% Pn.

2. Initial Condition Pout ≤ 80% Pn

3. @ Battery Fully Discharged. Call SOCOMECS UPS support service.

4. @ Battery Fully Charged. Call SOCOMECS UPS support service.

Socomec worldwide

IN WESTERN EUROPE

BELGIUM

B - 1190 Bruxelles
Tel. +32 (0)2 340 02 34
info.ups.be@socomec.com

FRANCE

F - 94132 Fontenay-sous-Bois Cedex
Tel. +33 (0)1 45 14 63 90
dcm.ups.fr@socomec.com

GERMANY

D - 68309 Mannheim
Tel. +49 (0) 621 71 68 40
info.ups.de@socomec.com

ITALY

20098 San Giuliano Milanese (MI)
Tel. +39 02 98 242 942
info.ups.it@socomec.com

PORTUGAL

2640-486 Mafra
Tel. +351 261 812 599
info.ups.pt@socomec.com

SPAIN

E - 08329 Teià (Barcelona)
Tel. +34 935 407 575
info.ups.sib@socomec.com

THE NETHERLANDS

NL - 3991 CD Houten
Tel. +31 (0)30 760 0911
info.ups.nl@socomec.com

UNITED KINGDOM

Cirencester - GL7 5XL
Tel. +44 (0)1285 863300
info.ups.uk@socomec.com

OTHER COUNTRIES

Tel. +34 935 407 575
info.ups.europe@socomec.com

IN EASTERN EUROPE, MIDDLE EAST, AFRICA

UNITED ARAB EMIRATES

371355 Dubai airport free zone
Dubai (United Arab Emirates)
Tel.: +971 (0) 4 29 98 441
info.ups.ae@socomec.com

POLAND

01-625 Warszawa
Tel. +48 22 825 73 60
info.ups.pl@socomec.com

ROMANIA

023383 Bucharest
Tel. +40 21 319 36 88 (89, 81, 82)
info.ups.ro@socomec.com

RUSSIA

125167 - Moscow
Tel. +7 495 775 19 85
info.ups.ru@socomec.com

SLOVENIA

SI - 1000 Ljubljana
Tel. +386 1 5807 860
info.ups.si@socomec.com

TURKEY

34357 Istanbul
Tel. +90 (0) 216 540 71 20
info.ups.tr@socomec.com

OTHER COUNTRIES

Tel. +39 0444 598 611
info.ups.emea@socomec.com

IN ASIA PACIFIC

AUSTRALIA

Macquarie Park NSW 2113
Tel. +61 2 9325 3900
info.ups.au@socomec.com

CHINA

Chaoyang, Beijing 100016 P.R., China
Tel. +86 10 59756108
info.ups.cn@socomec.com

INDIA

Guindy, Chennai - 600 032
Tel. +91 44 3921 5400
info.ups.in@socomec.com

MALAYSIA

47301 Petaling Jaya.- Selangor, Malaysia
Tel. +603 7804 0850
info.ups.my@socomec.com

SINGAPORE

Singapore 408694
Tel. +65 6506 7600
info.ups.sg@socomec.com

THAILAND

Chatujak Bangkok 10900
Tel. +66 2 941-1644-7
info.ups.th@socomec.com

VIETNAM

Ho Chi Minh City
Tel. +84-839734.990
info.ups.vn@socomec.com

ASIA PACIFIC HEAD OFFICE

Tel. +65 6507 9770
info.ups.apac@socomec.com

IN AMERICA

LATIN AMERICAN COUNTRIES

Tel. +34 935 407 575
info.ups.sib@socomec.com

HEAD OFFICE

SOCOMECE GROUP

S.A. SOCOMECE capital 10 951 300 €
R.C.S. Strasbourg B 548 500 149
B.P. 60010 - 1, rue de Westhouse - F-67235 Benfeld Cedex

SOCOMECE Strasbourg

11, route de Strasbourg - B.P. 10050 - F-67235 Huttenheim Cedex - FRANCE
Tel. +33 (0)3 88 57 45 45 - Fax +33 (0)3 88 74 07 90
admin.ups.fr@socomec.com

SOCOMECE Isola Vicentina

Via Sila, 1/3 - I - 36033 Isola Vicentina (VI) - ITALY
Tel. +39 0444 598611 - Fax +39 0444 598622
hr.ups.it@socomec.com

SALES, MARKETING AND SERVICE MANAGEMENT

SOCOMECE Paris

95, rue Pierre Grange
F-94132 Fontenay-sous-Bois Cedex - FRANCE
Tel. +33 (0)1 45 14 63 90 - Fax +33 (0)1 48 77 31 12
dcm.ups.fr@socomec.com

YOUR DISTRIBUTOR



IOMMASBCXX05-GB 02 01.2013

www.socomec.com



socomec
Innovative Power Solutions